



Serie 6

Polen-Litauen-Lettland

2022

Update-Service Woche / Week 36

Woche / Week 01-16 2022

Hinweis: Dieses Dokument enthält das bisherige, komplette Jahresupdate. Um unnötige Ausdrücke zu vermeiden, wird darauf hingewiesen, gemäß Bedarf nur die bislang noch nicht benutzten Seiten auszudrucken.

Note: This document contains the entire Update-Service to this date. To avoid unnecessary printouts, only the not yet corrected pages should be printed.

Södra Midsjöbanken:
 ODAS Tonne ausgelegt.
 ODAS buoy established.

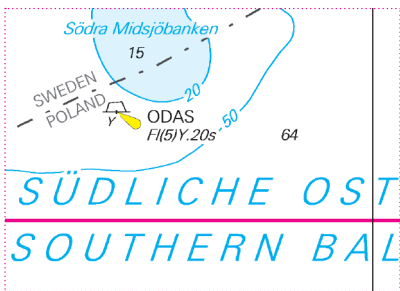

S1 Mitte
 S1 centre

Northeast of Stilo:
 ODAS Tonne eingezogen.
 ODAS buoys removed.

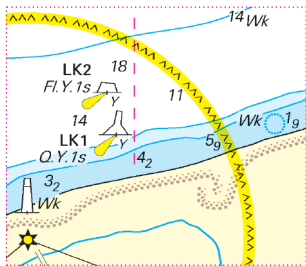

S4 Mitte
 S4 centre

Köiguste-Allirahu:
 Leuchtfeuerkennung angepasst.
 Light character amended.

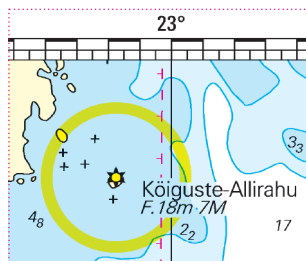

S9 oben rechts
 S9 top right

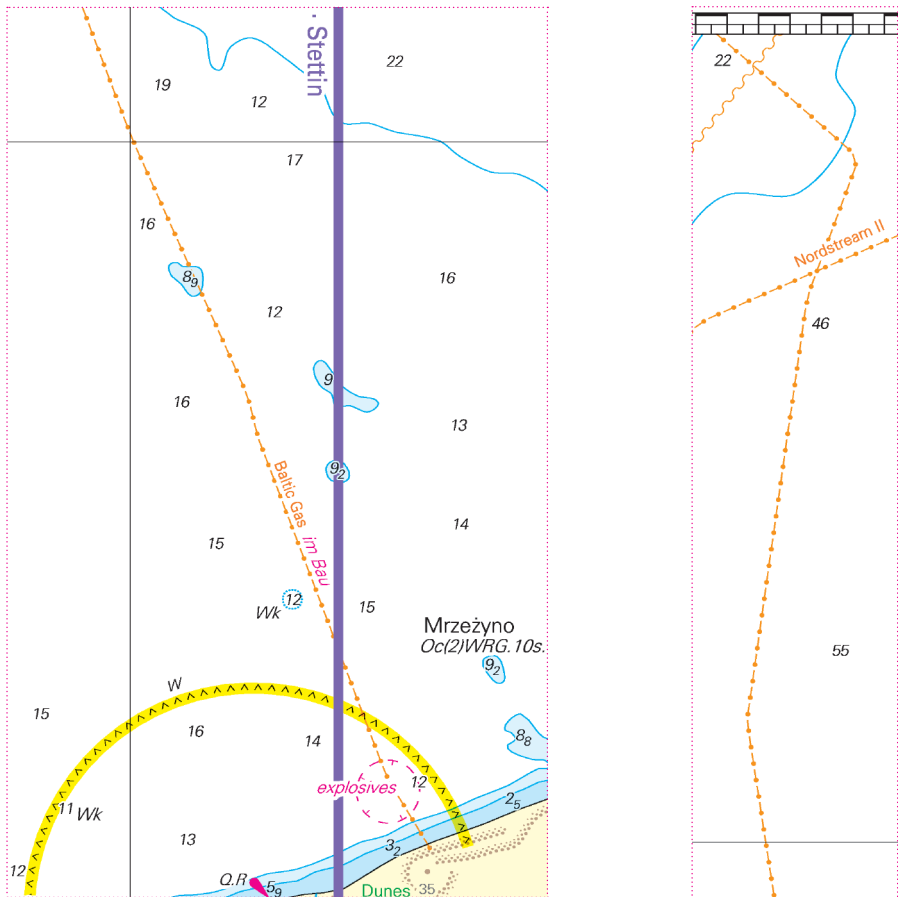

S3 unten links
 S3 bottom left

Zatoka Pomorska:
 Baltic Gas Pipeline eingetragen.
 Blatic Gas pipeline inserted.

S3 oben links
 S3 top left

NV Serie 4 · Rund Rügen · Boddengewässer

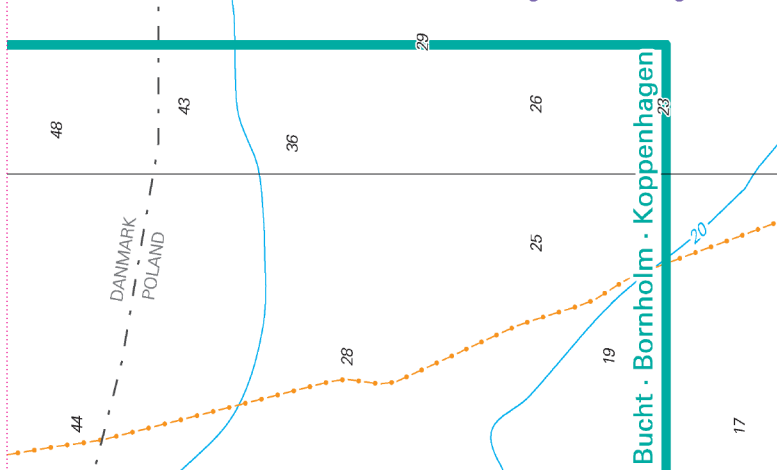

S3 Mitte links
 S3 centre left

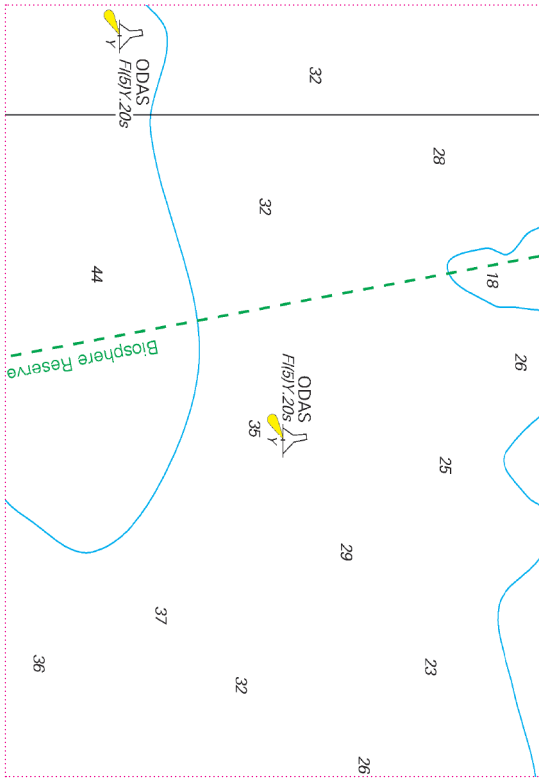

S8 Mitte
S8 centre

Southwest of Karala:
Messtonnen eingezogen.
Recording buoys removed.

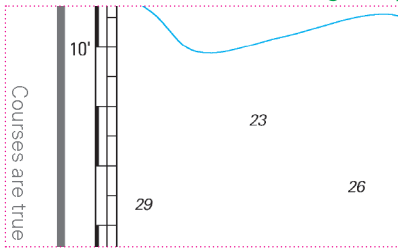

S9 oben links
S9 top left

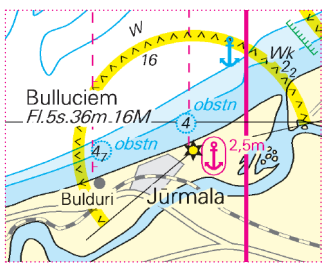

S10 unten Mitte
S10 bottom centre

North of Bulduri:
Unterwasserhinderniss eingefügt.
Obstruction added.

Dartowo:
Radarturm eingefügt.
Radar tower added.

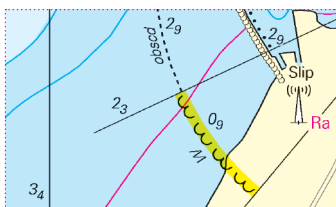

S11/1 oben links
S11/1 top left

Martwa Wisla:
Betonnung angepasst.
Buoyage amended.

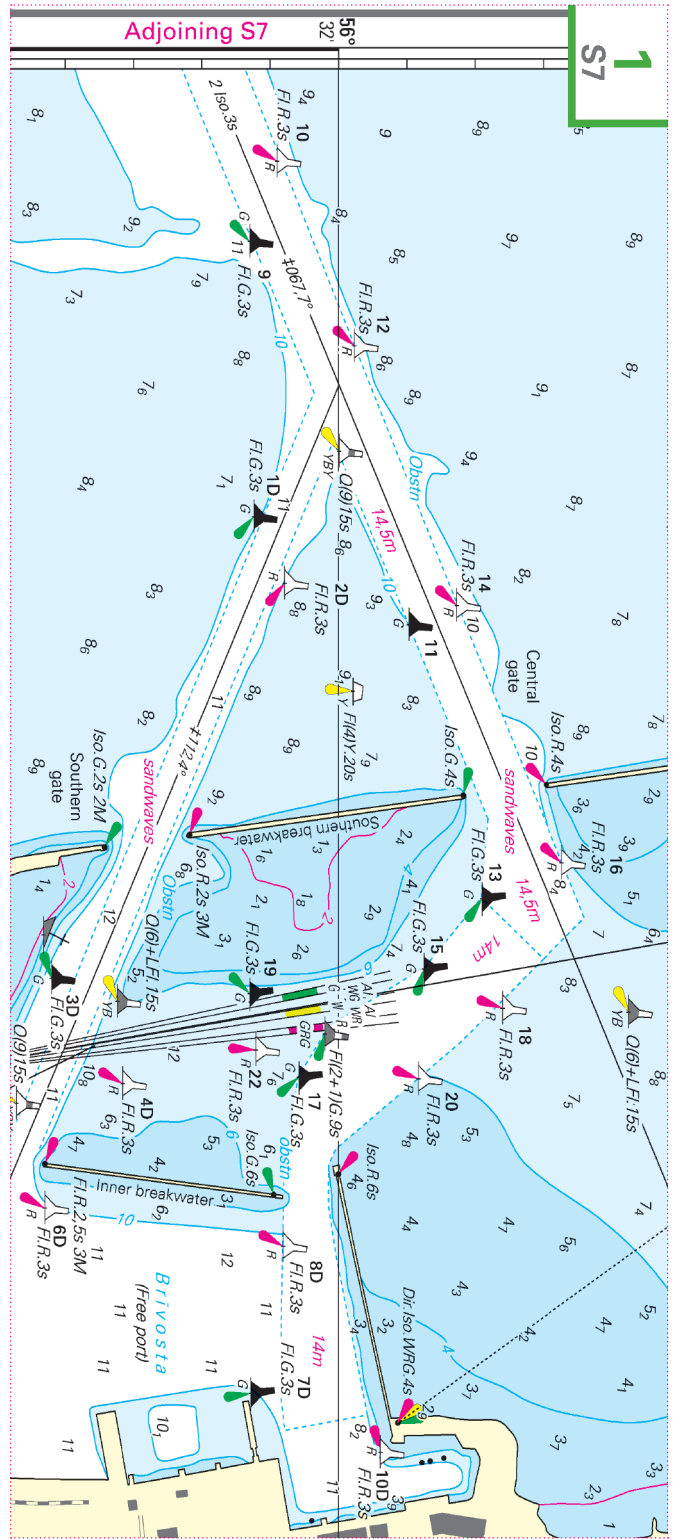

S15/1 Mitte
S15/1 centre

Liepaja:
Tiefenkontour und Lichtererkennung angepasst.
Depth contour and light character amended.

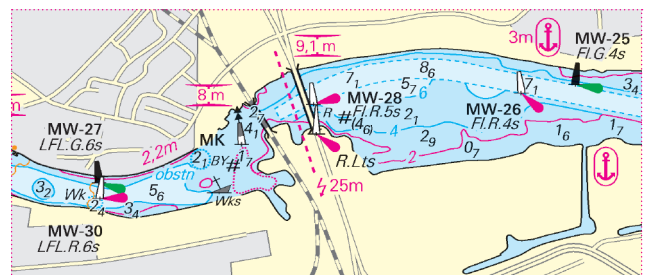

S13 unten Mitte
S13 bottom centre

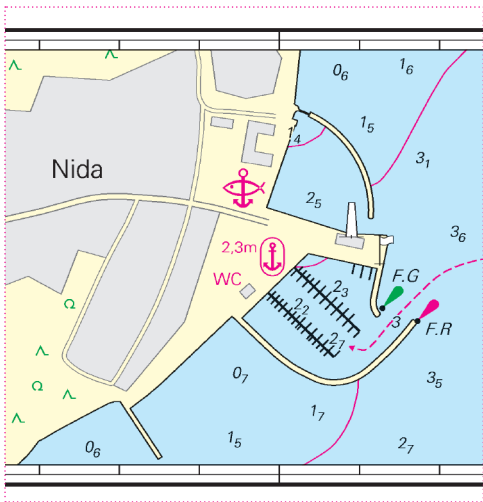

S15/2 Mitte
S15/2 centre

Nida:
Hafenplan angepasst.
Harbour map amended.

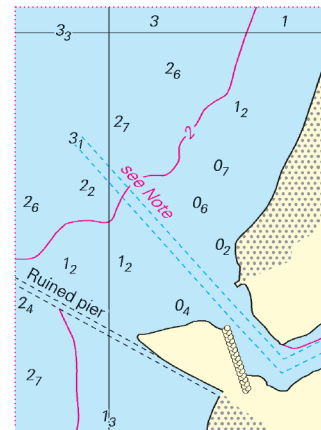

S15/3 Mitte
S15/3 centre

Svetoji:
Betonnung angepasst.
Buoyage amended.

Klaipeda:
Tonnenpositionen angepasst.
Buoyage amended.

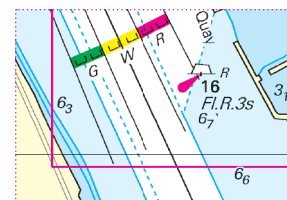

S16 Mitte
S16 centre

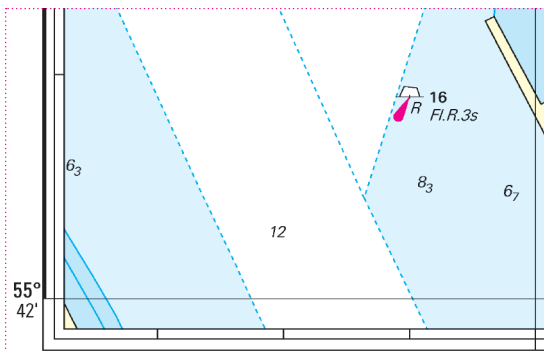

S15/4 unten links
S15/4 bottom left

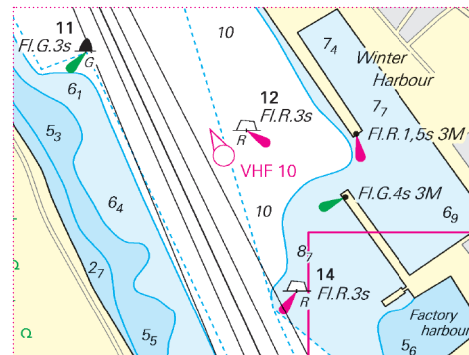

S16 Mitte
S16 centre

Mersrags:
Hafen angepasst.
Harbour amended.

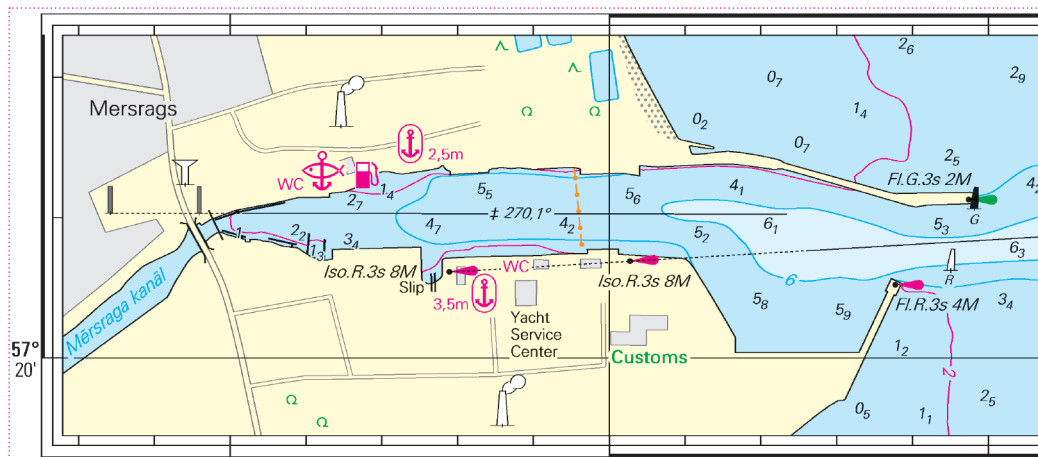

S17/6 links
S17/6 left

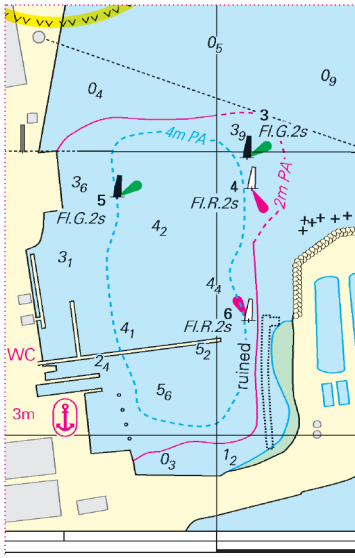

S177 unten Mitte
S177 bottom centre

Engure:
Hafenplan angepasst.
Harbour map amended.

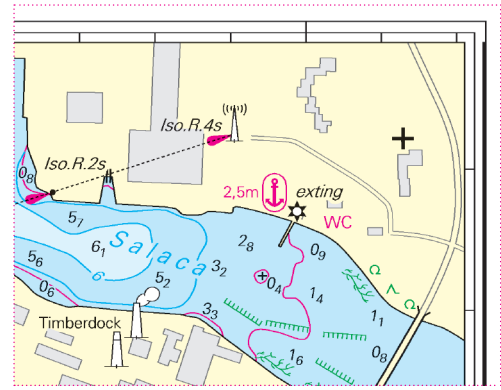

S179 oben rechts
S179 top right

Salacgriva:
Betonnung angepasst.
Buoyage amended.

Skulte:
Hafenplan angepasst.
Harbour map amended.

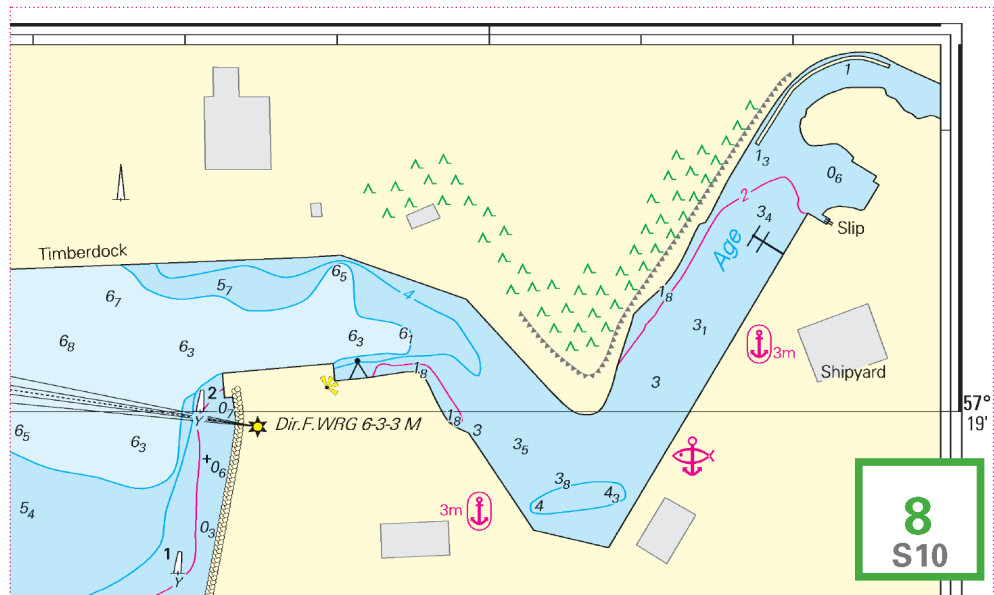

S178 Mitte rechts
S178 centre right

Daugava:
Molenfeuer gestrichen.
Mole head light removed.

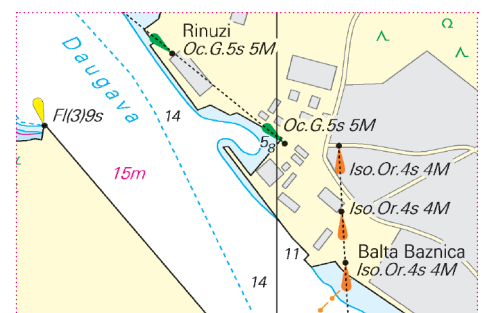

S18 Mitte rechts
S18 centre right

Zatoka Gdanska:
 Offshore Plattformen angepasst.
 Offshore platforms amended.

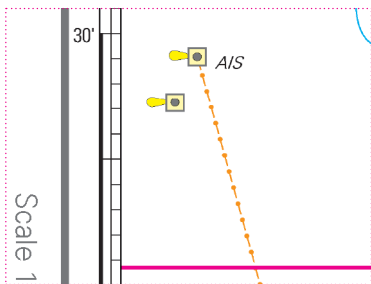

S2 Mitte links
 S2 centre left



S3 unten links
 S3 bottom left

Zatoka Pomorska:
 Sprengstoffbereich aufgehoben,
 Pipeline fertiggestellt.
 Explosives area cancelled,
 pipeline completed.

Kołobrzeg:
 Auslaufleitung verlegt.
 Outlet pipeline position amended.

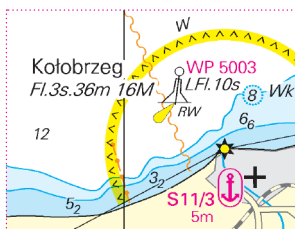

S3 unten Mitte
 S3 bottom centre

Zatoka Pucka:
 Fisch- und Tauchverbotsgebiet eingefügt.
 Fishing and diving prohibited area inserted.

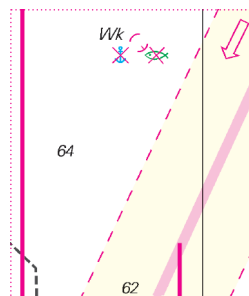

S5 unten links
 S5 bottom left

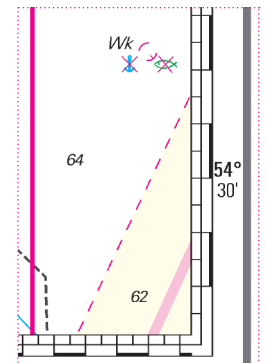

S4 unten rechts
 S4 bottom right

Zatoka Elblaska:
 Betonung angepasst.
 Buoyage amenden.

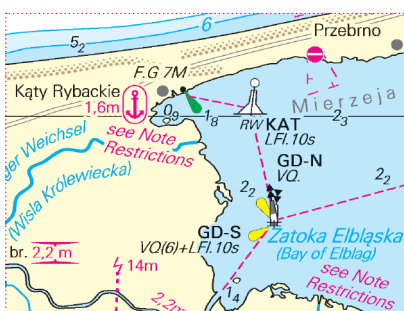

S5 unten Mitte
 S5 bottom centre

Köiguste-Allirahu:
 Leuchfeuer Position und Kennung angepasst.
 Lighthouse position and character amended.

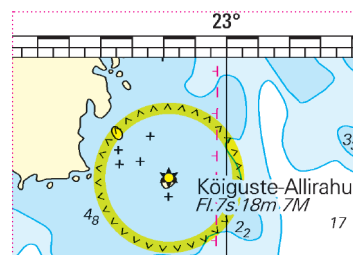

S9 oben rechts
 S9 top right

Sopot:

Betonnung und Tiefenkontour angepasst.
Buoyage and depth contour amended.

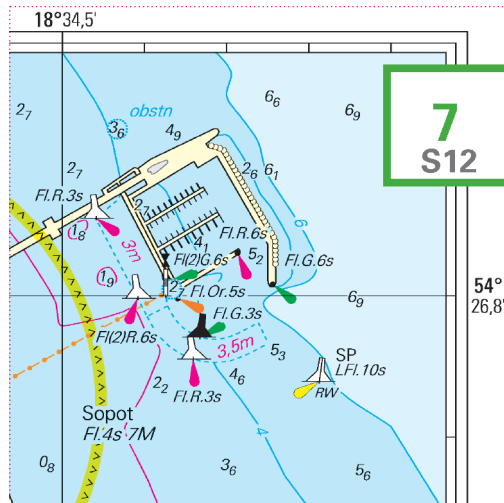

S11/7 oben rechts
S11/7 top right

Kuznica:

Betonnung angepasst
Buoyage amended.

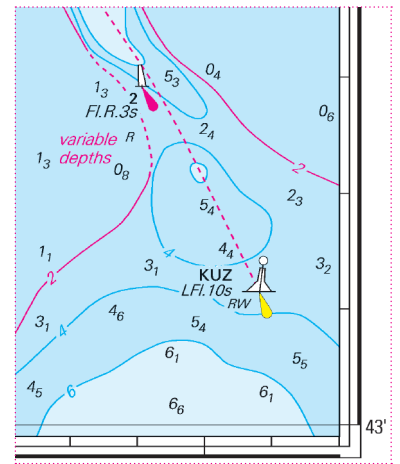

S11/11 unten rechts
S11/11 bottom right

Gdansk:

Hafenbecken benannt.
Port basin named.

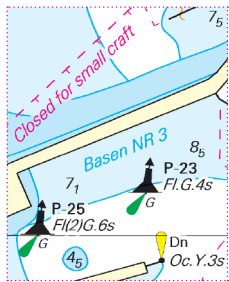

S13 oben Mitte
S13 top centre

Zatoka Pucka:

Betonnung angepasst.
Buoyage amended.

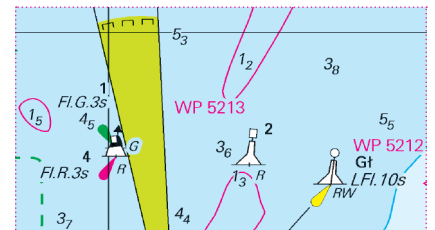

S12 Mitte links
S12 centre left

20cm
10cm

Liepaja:

Betonnung angepasst.
Buoyage amended.

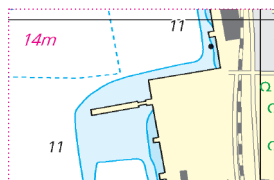

S15/1 Mitte
S15/1 centre

Gdansk:

Betonnung und Tiefenkontour angepasst.
Buoyage and depth contour amended.

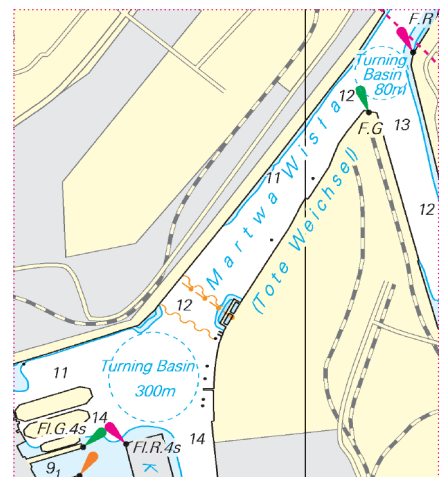

S13 Mitte links
S13 centre left

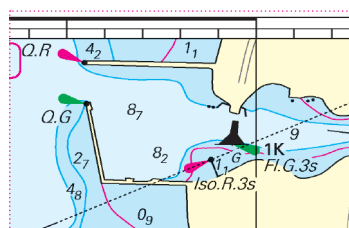

S15/1 oben rechts
S15/1 top right

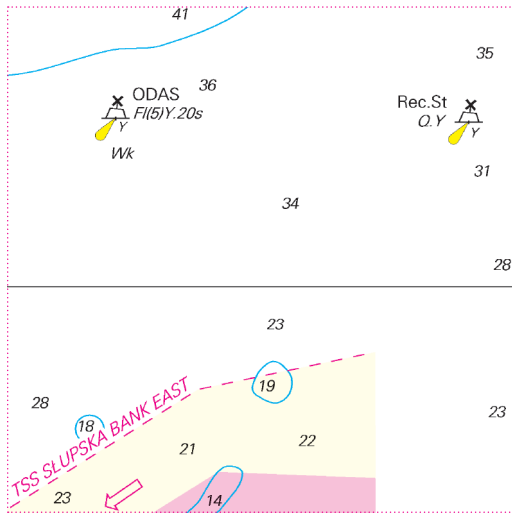

S4 Mitte
S4 centre
Nördlich/ north of Stilo:
Betonnte Messtelle eingerichtet.
Buoyed recording station established.

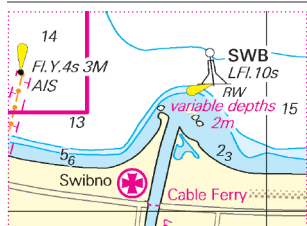

Przekop Wisly:
Betonnung angepasst.
Buoyage amended.

S5 unten Mitte
S5 bottom centre

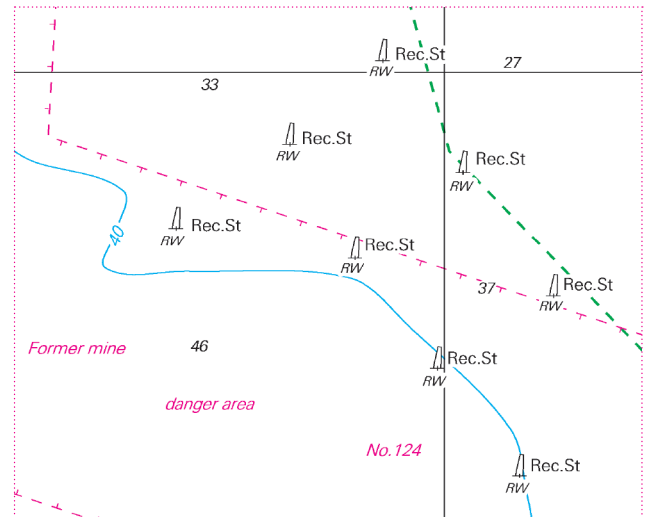

S6 oben Mitte
S6 top centre
Westlich/ West of Palanga:
Betonnte Messtellen eingerichtet.
Buoyed recording stations established.

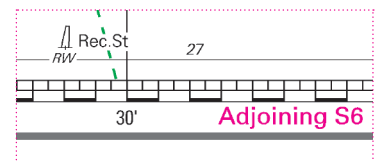

S7 unten links
S7 bottom left

Liepaja:
Lotsenversetzstelle "B" eingefügt.
Pilot boarding place "B" inserted.

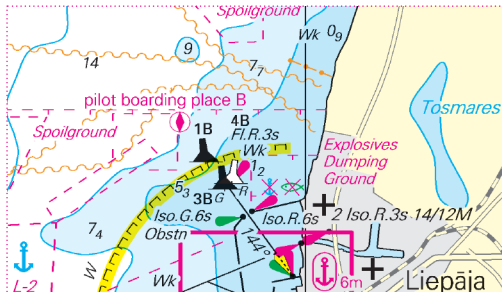

S7 Mitte
S7 centre

Roja:
Betonnung angepasst.
Buoyage amended.

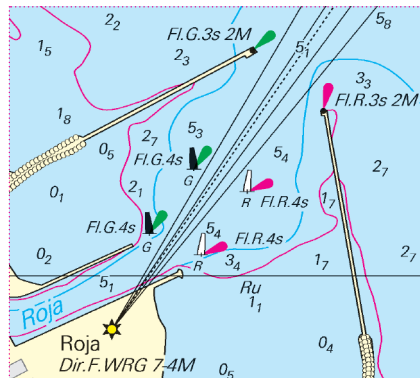

S17/5 Mitte
S17/5 centre

Jastarnia:
Unreinstellen eingefügt.
Foul grounds inserted.

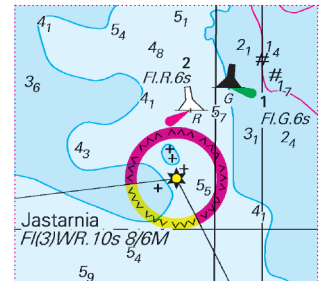

S11/10 unten Mitte
S11/10 bottom centre

Liepaja:
Betonnung angepasst, Lotsenversetzstelle "C" eingefügt.
Buoyage amended, pilot boarding place "C" inserted.

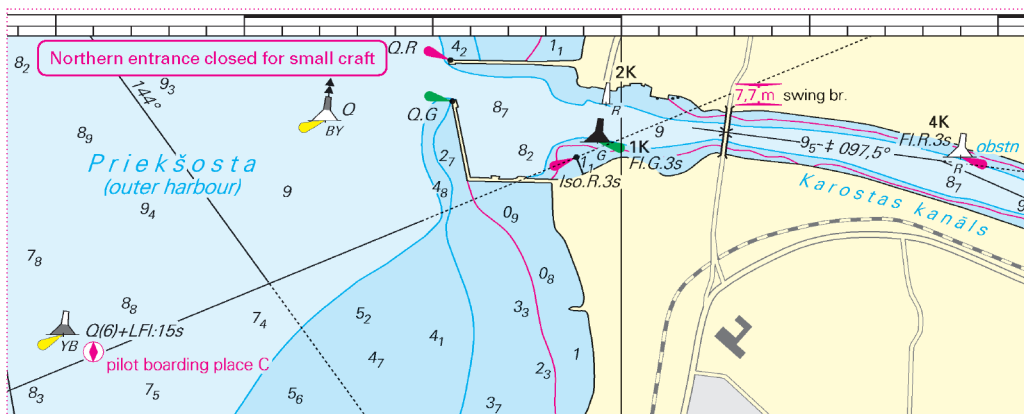

S15/1 oben rechts
S15/1 top right

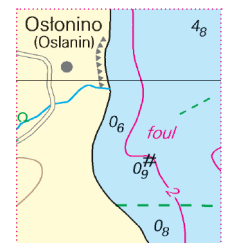

S12 Mitte links
S12 centre left

Zatoka Pucka:
Unreinstelle eingefügt.
Foul ground inserted.
Kontrollskala für Druck / control scale for print

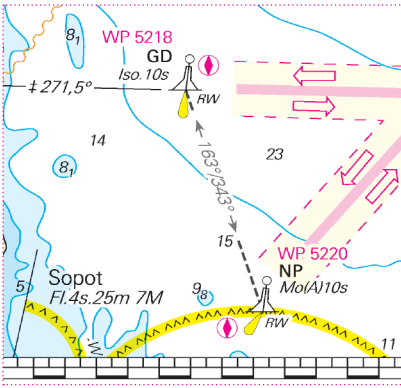

S4 unten rechts
S4 bottom right

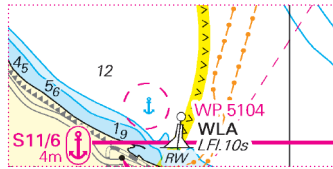

S4 Mitte
S4 centre

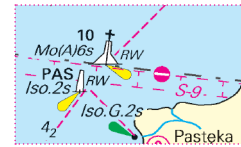

S5 unten Mitte
S5 bottom centre

Danziger Bucht / Bay of Gdansk:
Betonnung angepasst.
Buoyage amended.

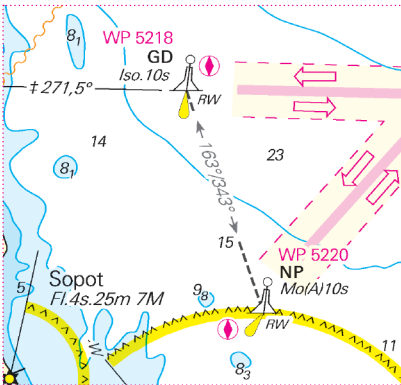

S5 unten links
S5 bottom left

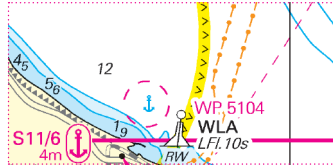

S5 oben links
S5 top left

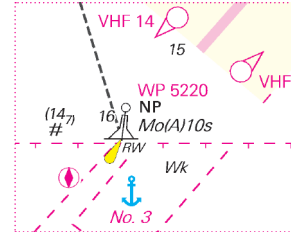

S12 unten Mitte
S12 bottom centre

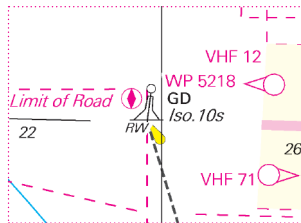

S12 Mitte
S12 centre

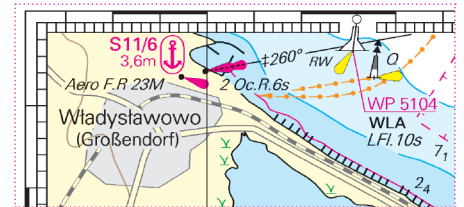

S12 oben links
S12 top left

Südöstlich / south east of Ruhnu:
Betonnung angepasst.
Buoyage amended.

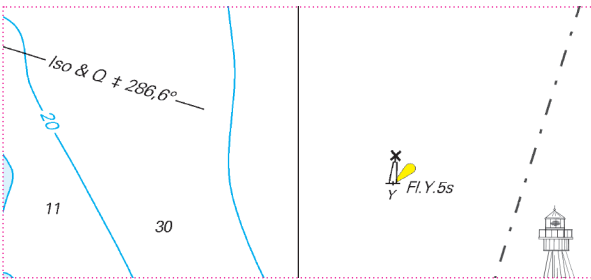

S10 oben links
S10 top left

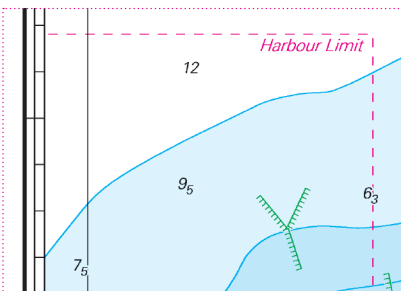

S18 Mitte links
S18 centre left

Lielupe Mündung / Lielupe estuary:
Betonnung angepasst.
Buoyage amended.

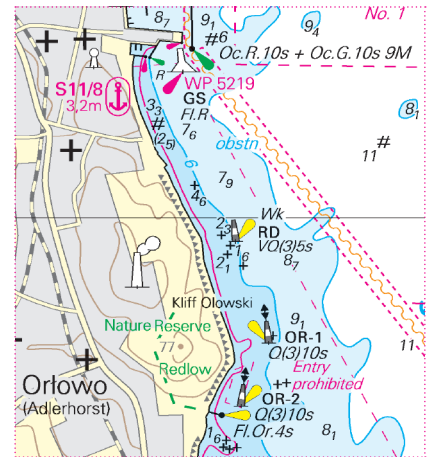

S12 Mitte links
S12 centre left

Gdynia:
Betonnung angepasst, Unterwasserstein eingetragen.
Buoyage amended, underwater rock inserted.



Baltic Serie 6

Polen · Litauen · Lettland

2023

Update-Service Woche / Week 38

Woche / Week 01-16 2023

Hinweis: Dieses Dokument enthält das bisherige, komplette Jahresupdate. Um unnötige Ausdrücke zu vermeiden, wird darauf hingewiesen, gemäß Bedarf nur die bislang noch nicht benutzten Seiten auszudrucken.

Note: This document contains the entire Update-Service to this date. To avoid unnecessary printouts, only the not yet corrected pages should be printed.

Nordwestlich / northwest of Åland:
Leuchtturm Sälskär erloschen.
Lighthouse Sälskär extinguished.



S0 oben Mitte
S0 top centre

Nordwestlich / northwest of Kaliningrad:
Passe Namen an.
Amend Name.



S1 Mitte
S1 centre

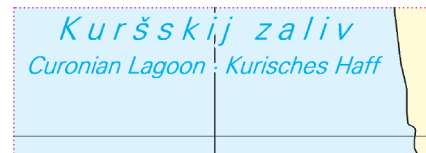

S2 unten rechts
S2 bottom right

Westlich / west of Krynica Morska:
Füge Schleuse und Insel ein.
Insert lock and island.



S1 unten Mitte
S1 bottom centre

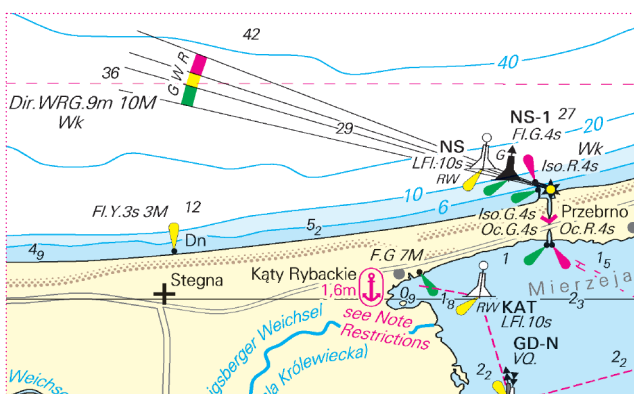

S5 unten Mitte
S5 bottom centre



S5 unten Mitte
S5 bottom centre

Niechorze:
Passe Befeuern an.
Amend lit.

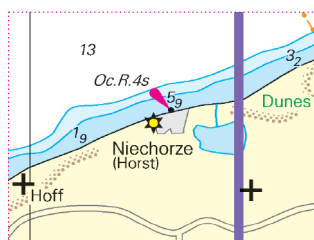

S3 unten links
S3 bottom left

Rozewie:
Füge Tonne ein.
Insert buoy.

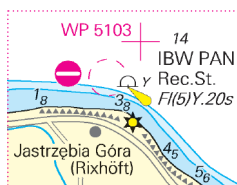

S4 Mitte
S4 centre

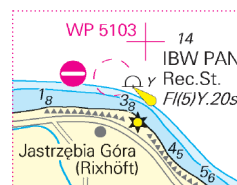

S5 Mitte links
S5 centre left

Nördlich / north of Rozewie:
 Passe Lage der Plattform an.
 Amend platform position.

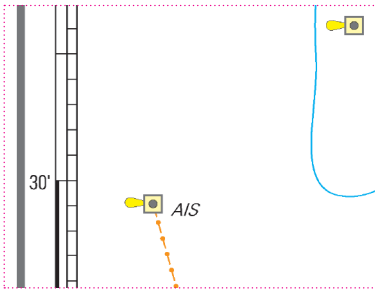

S2 Mitte links
 S2 centre left

Nördlich / north of Nida:
 Streiche Wrack.
 Delete wreck.

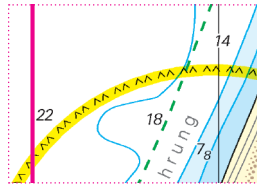

S6 Mitte rechts
 S6 centre right

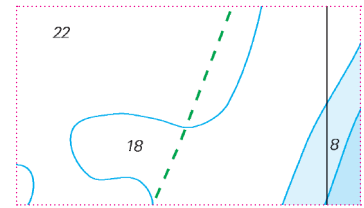

S14 unten links
 S14 bottom left

Nordwestlich / northwest
 of Klaipėda:
 Füge Tonnen ein.
 Insert buoys.

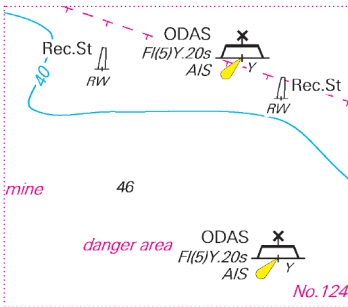

S6 oben Mitte
 S6 top centre

Westlich / west of Užava:
 Streiche Wrack.
 Delete wreck.

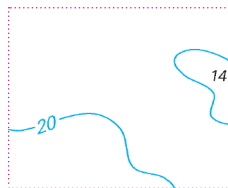

S7 oben Mitte
 S7 top centre

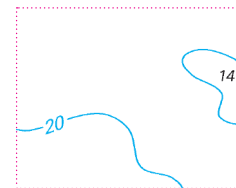

S8 unten Mitte
 S8 bottom centre

Östlich / east of Roja:
 Streiche Hindernis.
 Delete obstruction.

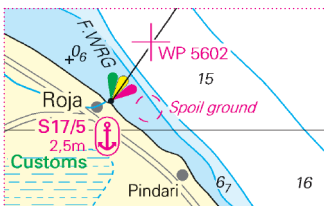

S9 Mitte rechts
 S9 centre right

Utska:
 Füge Befeuerung ein.
 Insert lit.

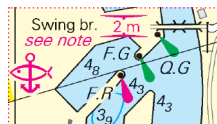

S11 Plan4 Mitte
 S11 Plan4 centre

Leba:
 Füge Befeuerung ein.
 Insert lit.

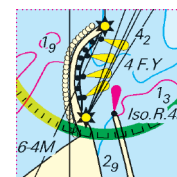

S11 Plan5 oben Mitte
 S11 Plan5 top centre

Gdynia:
 Füge Tiefenzahl ein.
 Insert sounding.

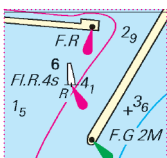

S11 Plan8 oben Mitte
 S11 Plan8 top centre

Gdansk:
 Passe Brückendurchfahrtshöhe an.
 Amend bridge clearance.

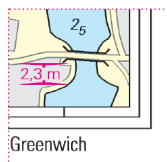

S13 PlanA unten rechts
 S13 PlanA bottom right

Salacgriva:
 Füge Slip ein.
 Insert slip.

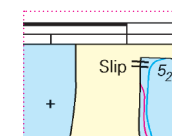

S17 Plan9 oben Mitte
 S17 Plan9 top centre

Westlich / west of
Gdynia:
Streiche Tonne.
Delete buoy.

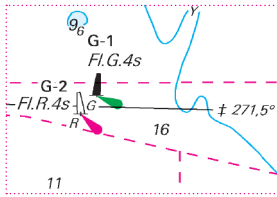

S12 Mitte
S12 centre

Wisła Śmiała:
Passe Hafen an.
Amend harbour.

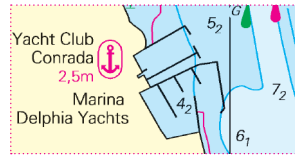

S13 PlanB Mitte
S13 PlanB centre

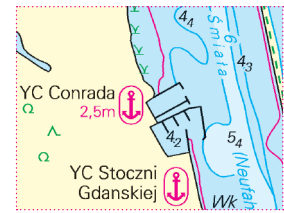

S13 unten Mitte
S13 bottom centre

Kuźnica:
Füge Tonne und Wrack ein.
Insert buoy and wreck.

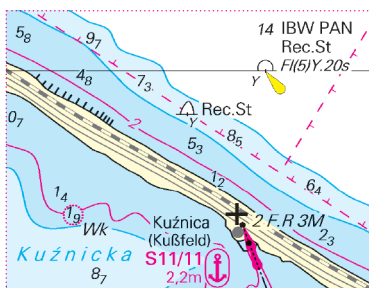

S12 oben links
S12 top left

Wisła Śmiała:
Streiche Wrack und Hindernis.
Delete wreck and obstruction.



S13 unten Mitte
S13 bottom centre

Südwestlich / south west
of Saaremaa:
Streiche Tonne.
Delete buoy.

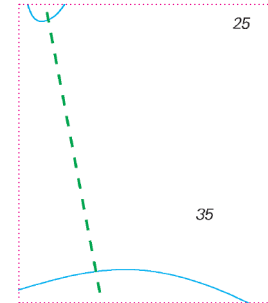

S8 oben Mitte
S8 top centre

Riga (Daugave):
Passe Tonnenlage an.
Amend buoy position.

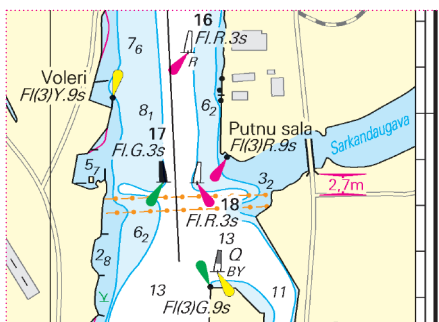

S18 Mitte rechts
S18 centre right

Gdansk (Port Północny):
Füge Befeuerung ein und passe
Befeuerung an.
Insert lit and amend lit.

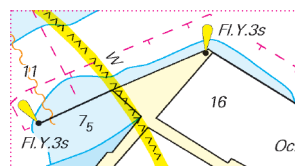

S13 oben Mitte
S13 top centre

Gdansk (Martwa Wisła):
Passe Küstenlinie an und füge
Tonne ein.
Amend coastline and insert buoy.

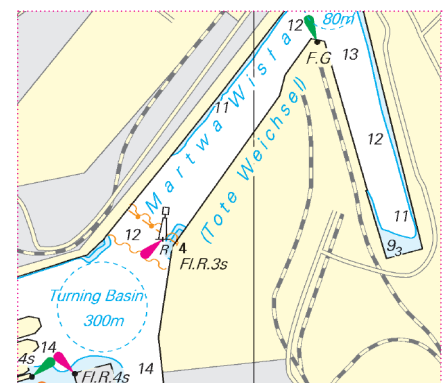

S13 Mitte links
S13 centre left

Martwa Wisła:
Füge Hafen ein.
Insert harbour.

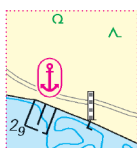

S13 unten rechts
S13 bottom right

Liepaja:
Füge Stege ein.
Insert jetties.

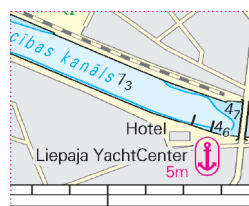

S15 Plan1 unten rechts
S15 Plan1 bottom right

Bay of Gdansk:
 Plattform versetzt.
 Oil rig moved.

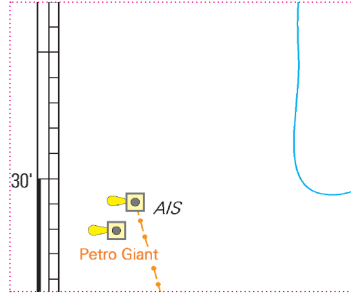

S2 Mitte links
 S2 centre left

Zatoka Pucka:
 Fischzuchtgebiet angepasst.
 Marine farm amended.

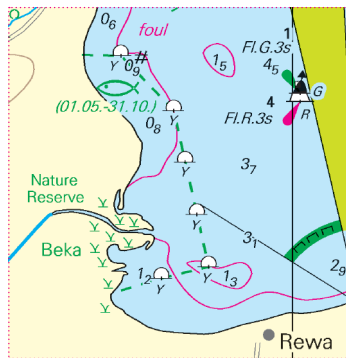

S12 Mitte links
 S12 centre left

Gdansk:
 Befeuerung eingefügt.
 Light inserted.

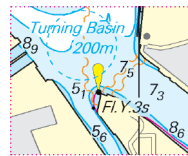

S13 unten links
 S13 bottom left

Wisla Smiala:
 Betonung angepasst.
 Buoyage amended.

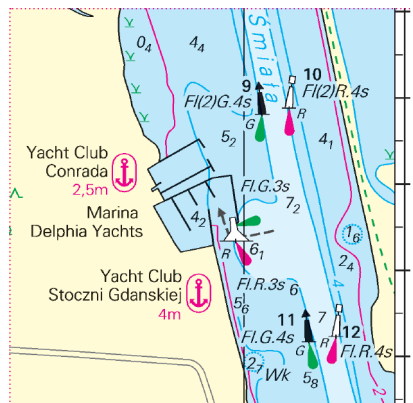

S13 B Mitte
 S13 B centre

Östlich / east of Gdansk:
Passe Tonnenlage an.
Amend buoy position.

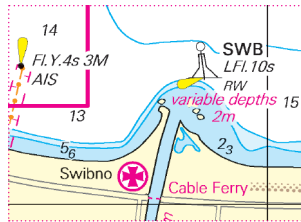

S5 unten links
S5 bottom left

20cm

10cm

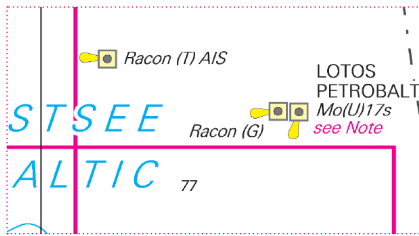

S1 unten Mitte
S1 bottom centre

Südliche Ostsee:
Plattform verlegt.
Offshore platform moved.

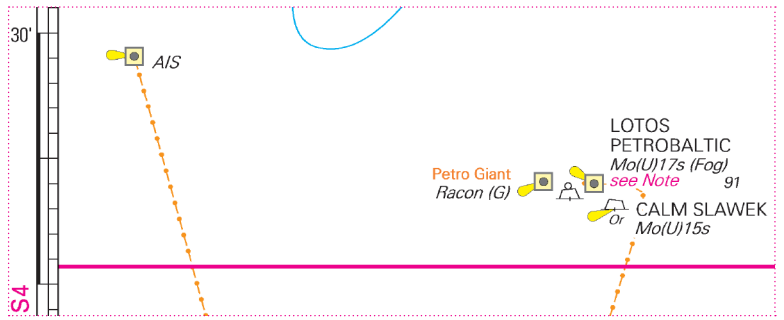

S2 Mitte links
S2 centre left

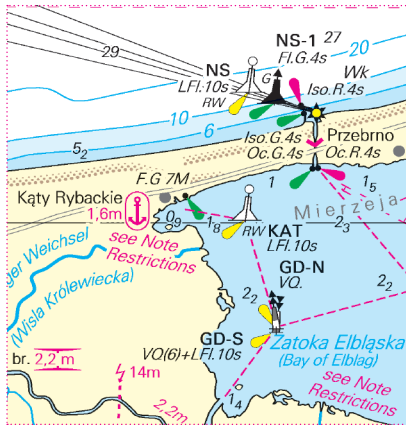

S5 unten Mitte
S5 bottom centre

Bay of Elblag:
Fahrwasser eingefügt.
Fairway added.

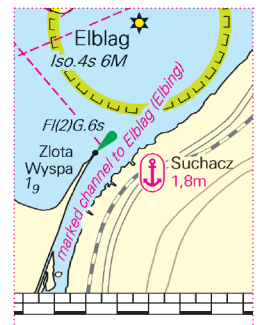

S5 unten Mitte
S5 bottom centre

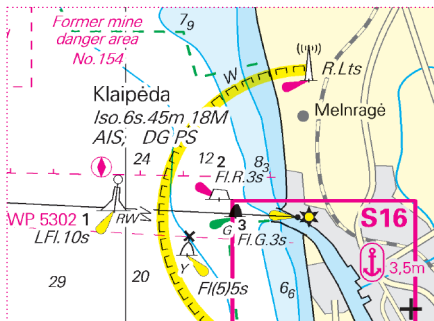

S6 Mitte rechts
S6 centre right

Klaipėda:
Betonnung angepasst, Pfähle eingefügt.
Buoyage amended, piles added.

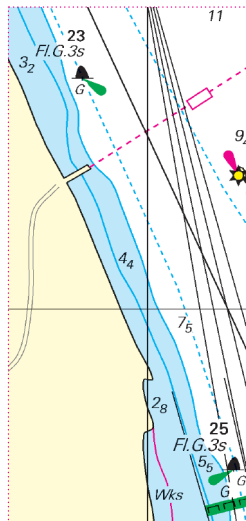

S16 Mitte rechts
S16 centre right

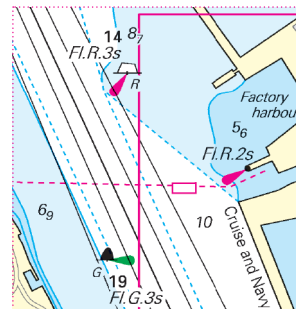

S16 Mitte
S16 centre

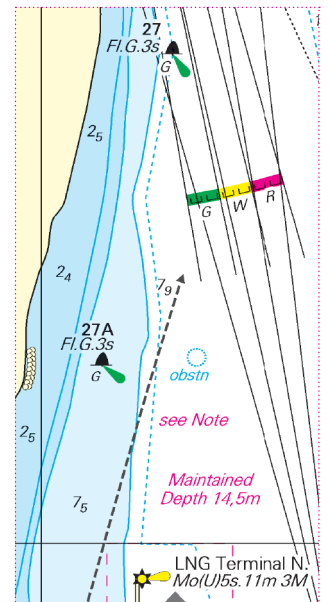

S16 unten rechts
S16 bottom right

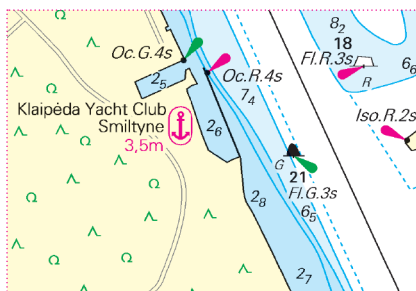

S16 Mitte
S16 centre

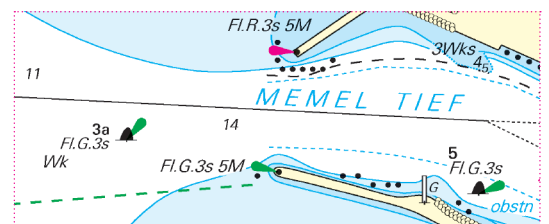

S16 oben links
S16 top left

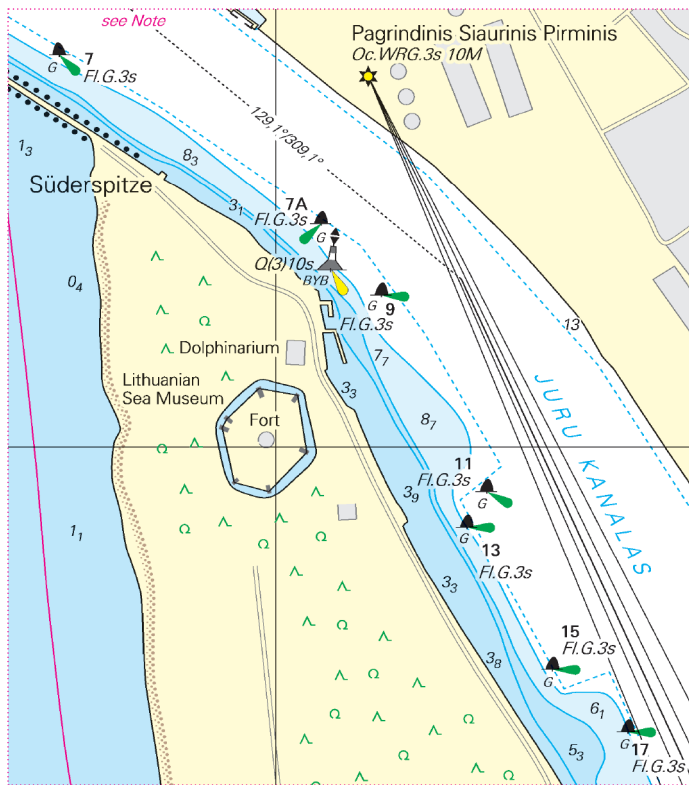

Klaipeda:
 Betonung angepasst, Pfähle eingefügt.
 Buoyage amended, piles added.

S16 oben Mitte
 S16 top centre

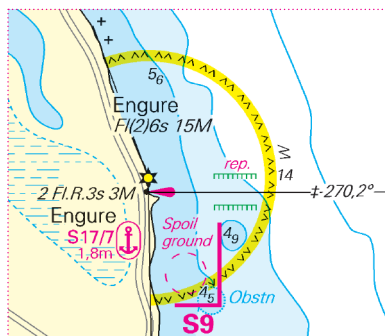

S10 unten links
 S10 bottom left

Engure:
 Befehung angepasst.
 Lights amended.

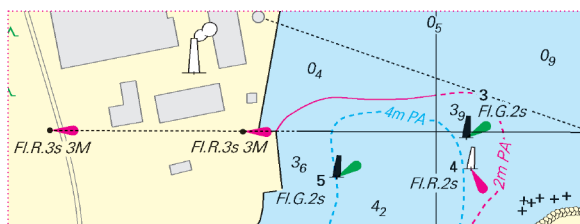

S17/7 Mitte links
 S17/7 centre left

Gdansk:
 Pfähle entfernt.
 Piles removed.

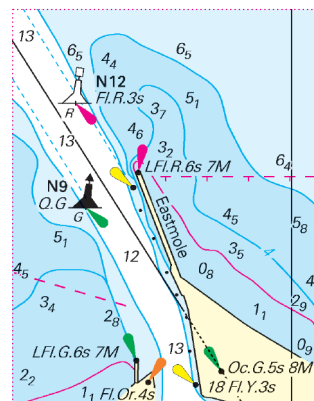

S13 oben links
 S13 top left

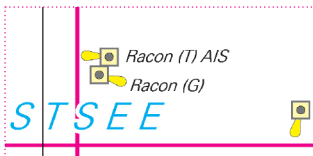

S1 unten Mitte
S1 bottom centre

Südliche Ostsee:
Plattform verlegt.
Offshore platform moved.

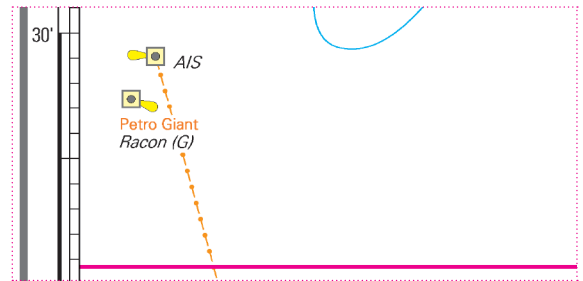

S2 Mitte links
S2 centre left

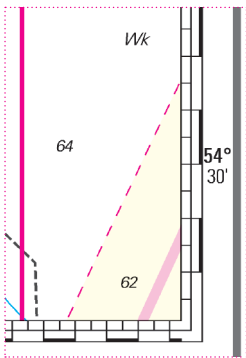

S4 unten rechts
S4 bottom right

Zatoka Gdanska:
Verbotzone gestrichen.
Restricted area removed.

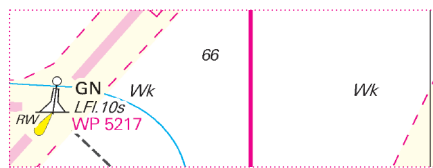

S5 Mitte
S5 centre

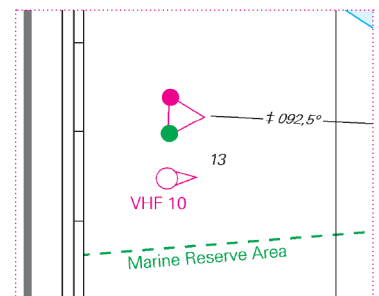

S16 oben links
S16 top left

Gdynia:
Mast gestrichen, Betonung angepasst.
Mast deleted, buoyage amended.

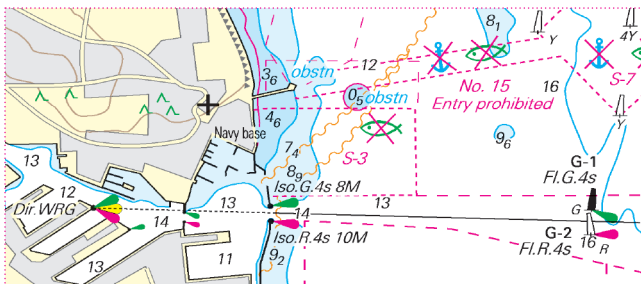

S12 Mitte
S12 centre

Klaipėda:
Betonung angepasst.
Buoyage amended.

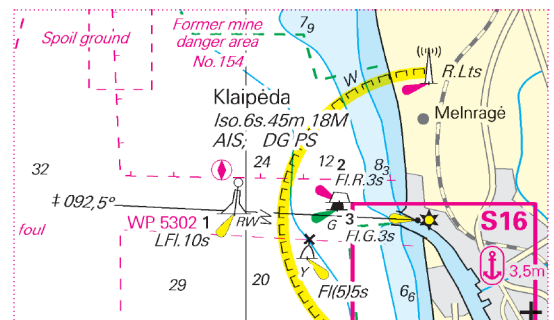

S6 unten rechts
S6 bottom right

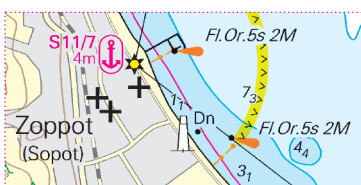

S12 unten Mitte
S12 bottom centre

Zoppot:
Dalben eingefügt.
Dolphin inserted.

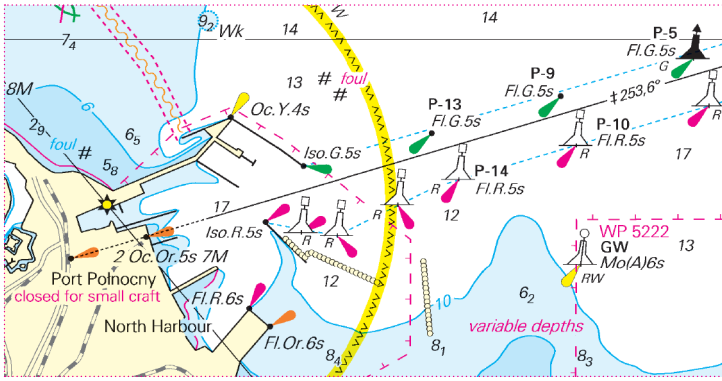

S12 unten Mitte
S12 bottom centre

Port Północny:
Betonnung angepasst.
Buoyage amended.

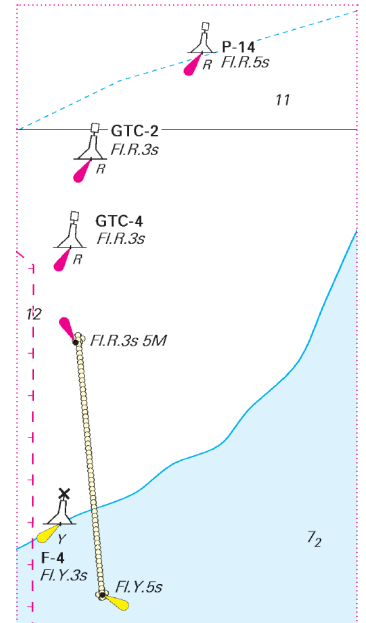

S13 Mitte
S13 centre

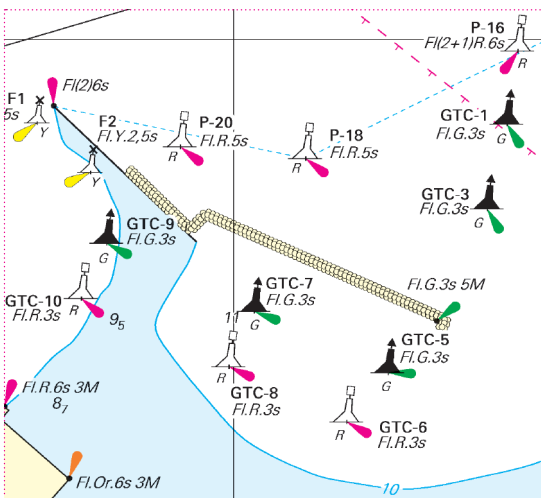

S13 Mitte
S13 centre

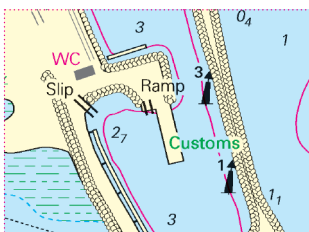

S17/4 Mitte
S17/4 centre

Ruhunu:
Betonnung angepasst.
Buoyage amended.

Darłowo:
Betonnung angepasst.
Buoyage amended.

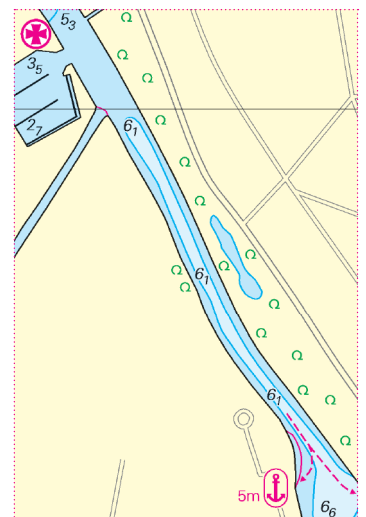

S11/1 Mitte
S11/1 centre



NVCharts

Baltic Serie 6 Polen · Litauen · Lettland 2024

Update-Service Woche / Week 37

Woche / Week 01-16 2024

Hinweis: Dieses Dokument enthält das bisherige, komplette Jahresupdate. Um unnötige Ausdrücke zu vermeiden, wird darauf hingewiesen, gemäß Bedarf nur die bislang noch nicht benutzten Seiten auszudrucken.

Note: This document contains the entire Update-Service to this date. To avoid unnecessary printouts, only the not yet corrected pages should be printed.

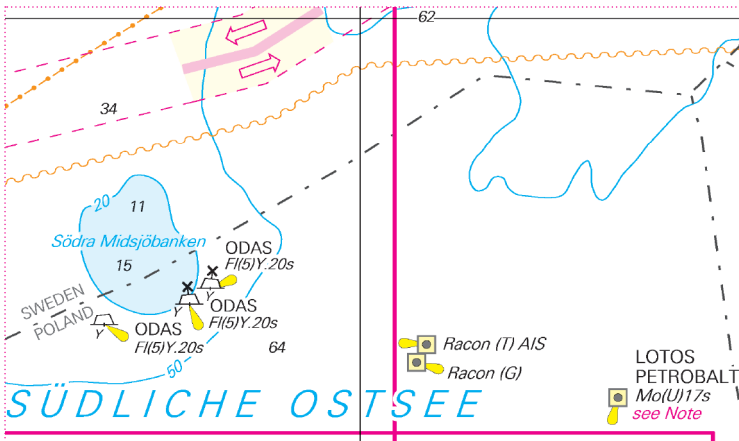

S1 Mitte
S1 centre

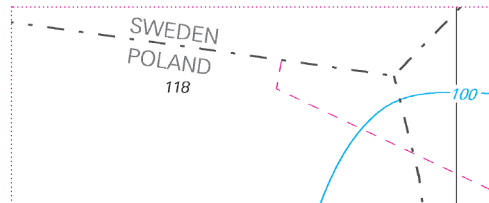

S2 Mitte links
S2 centre left

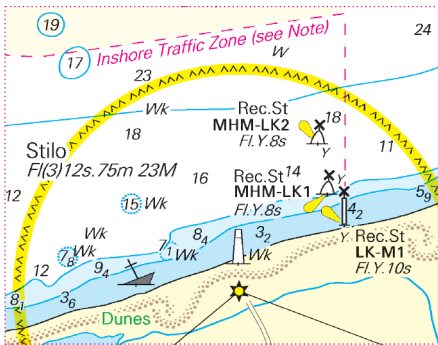

S4 Mitte
S4 centre

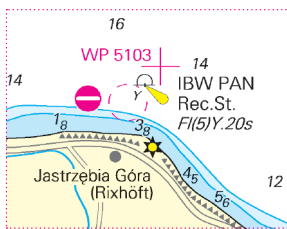

S4 Mitte rechts
S4 centre right

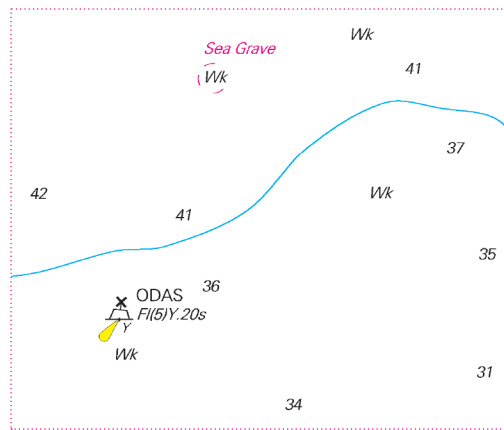

S4 Mitte
S4 centre

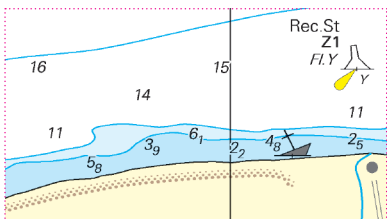

S4 Mitte
S4 centre



S5 unten Mitte
S5 bottom centre

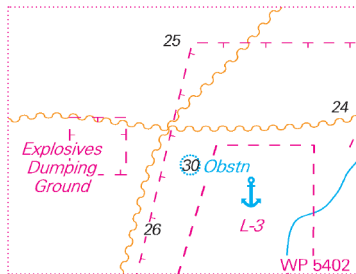

S7 Mitte
S7 centre

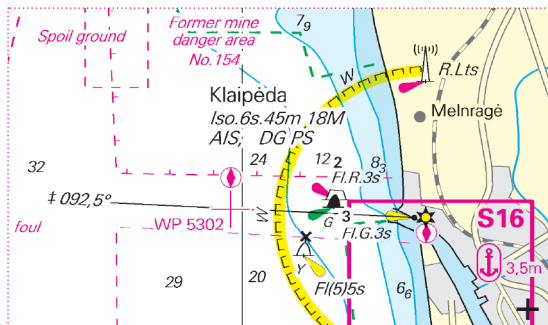

S6 Mitte rechts
S6 centre right

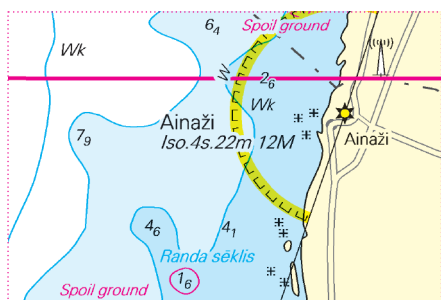

S10 oben rechts
S10 top right

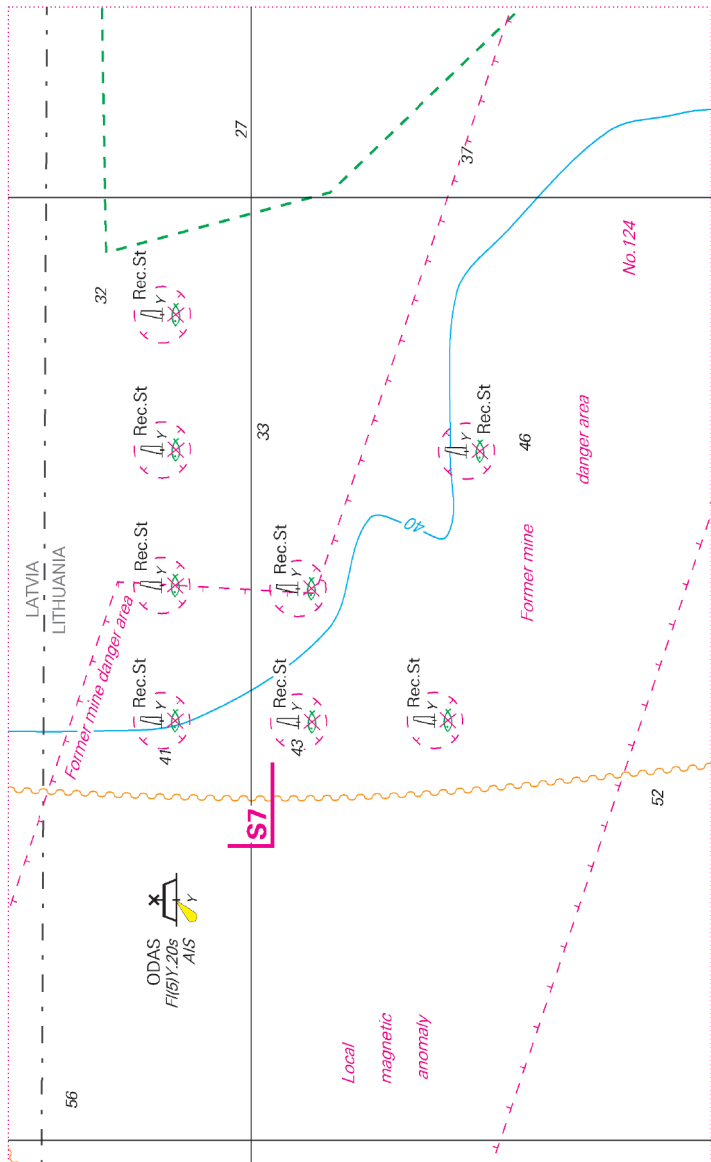

S6 oben links
S6 top left

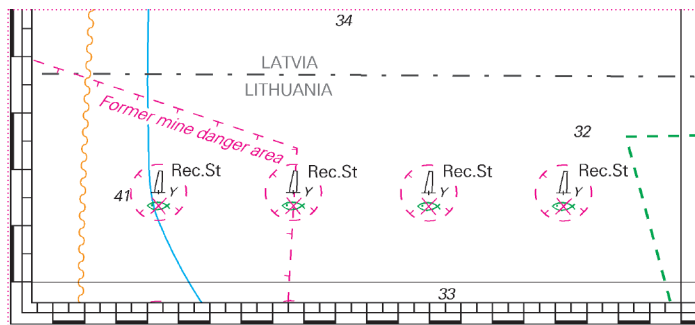

S7 unten links
S7 bottom left

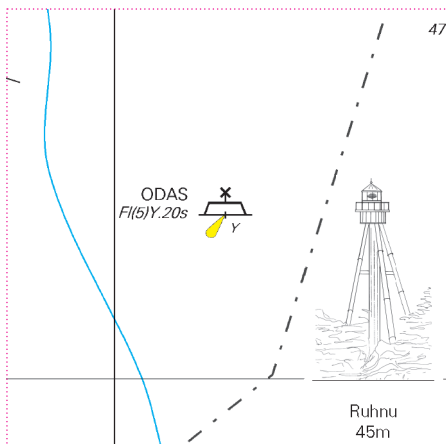

S10 Mitte links
S10 centre left

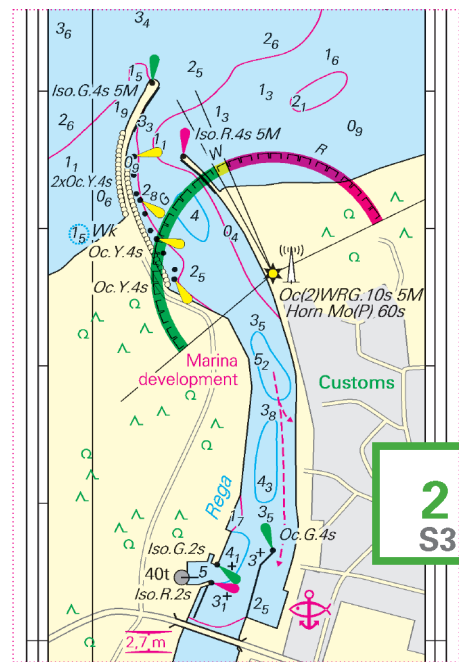

S11/2 Mitte
S11/2 centre

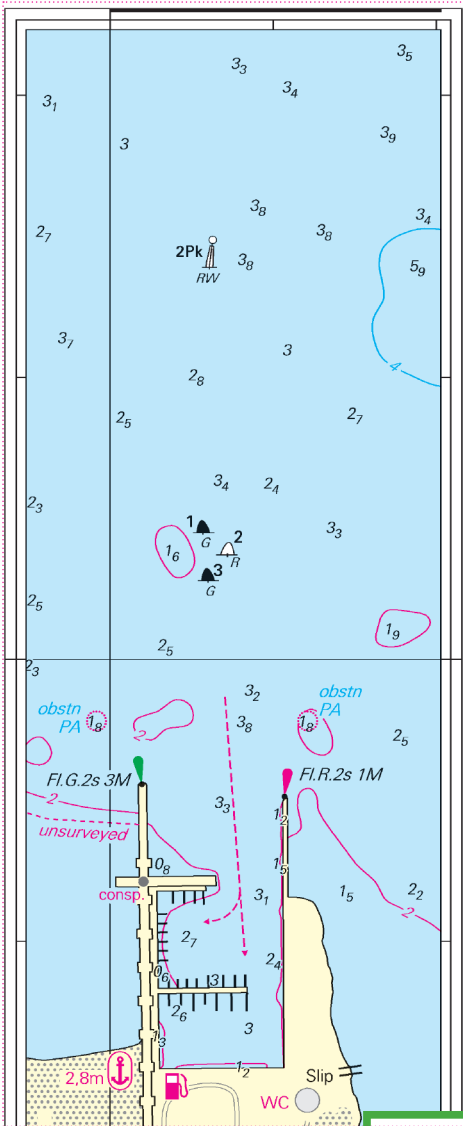

S11/9 oben Mitte
S11/9 top centre

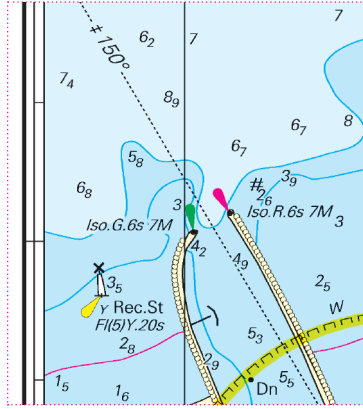

S11/4 oben links
S11/4 top left

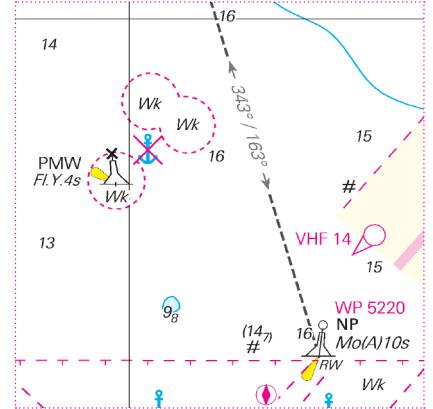

S12 unten Mitte
S12 bottom centre

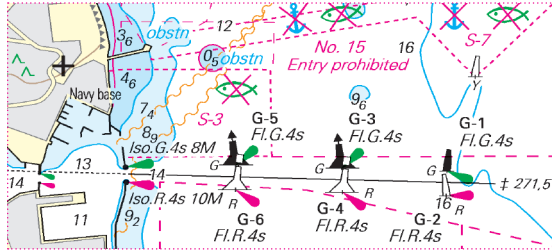

S12 Mitte links
S12 centre left

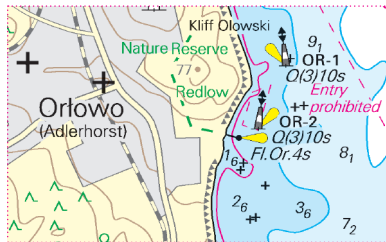

S12 unten Mitte
S12 bottom centre

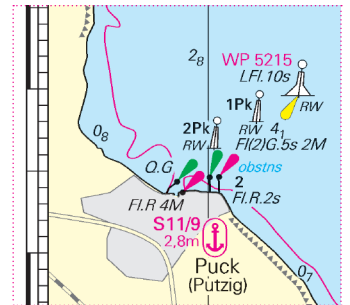

S12 oben links
S12 top left

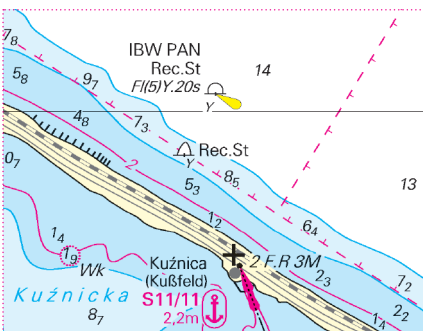

S12 oben Mitte
S12 top centre

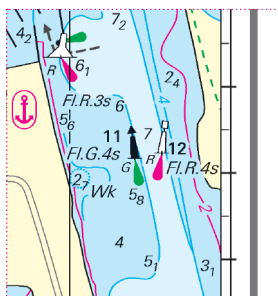

S13B unten rechts
S13B bottom right

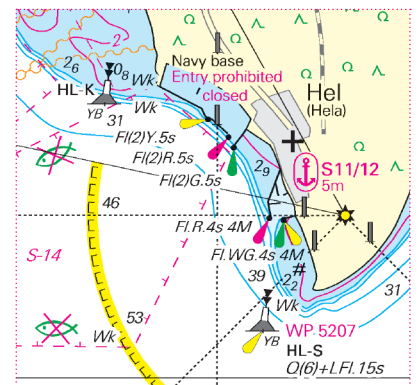

S12 Mitte rechts
S12 centre right

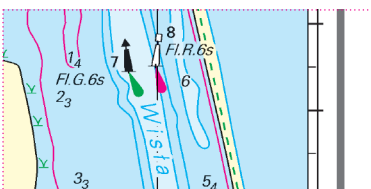

S13B Mitte rechts
S13B centre right

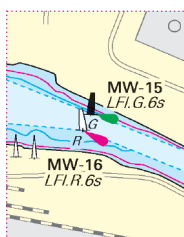

S13 unten Mitte
S13 bottom centre

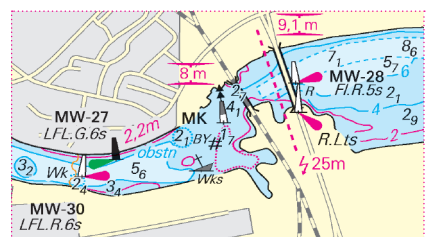

S13 unten links
S13 bottom left

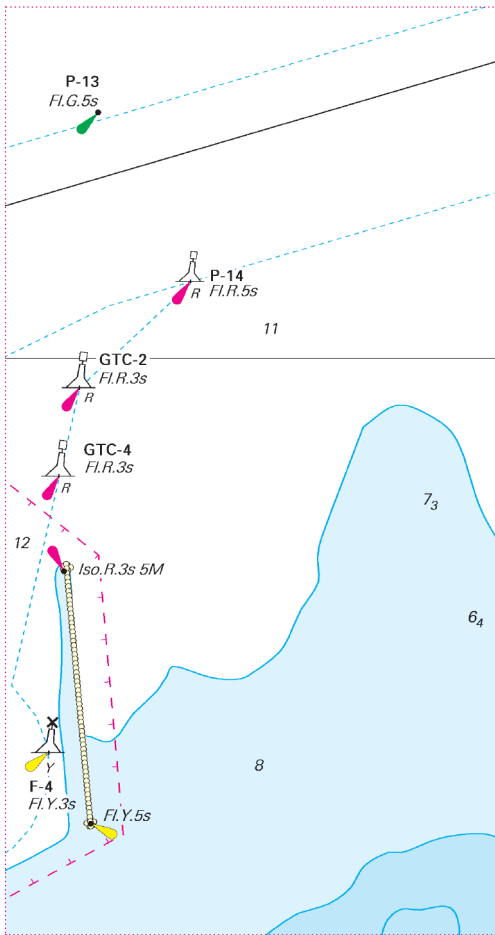

20cm

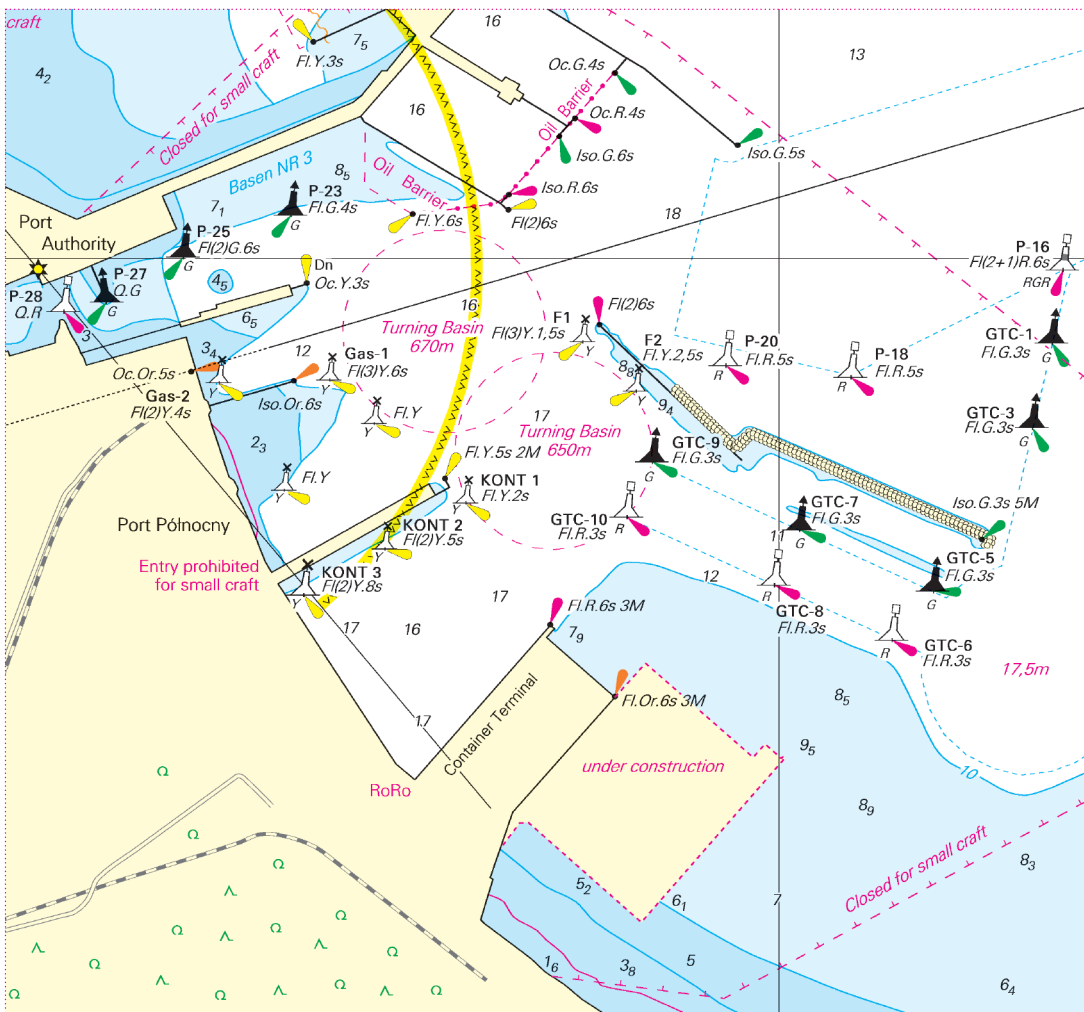

10cm

S13 Mitte
S13 centre

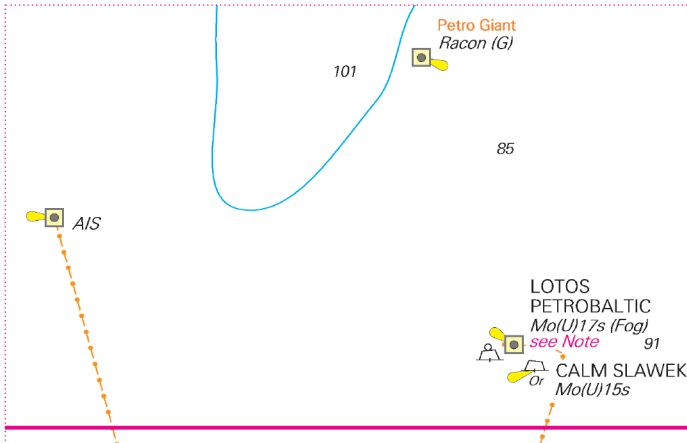

S2 Mitte links
S2 centre left

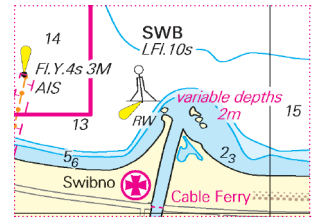

S5 unten Mitte
S5 bottom centre

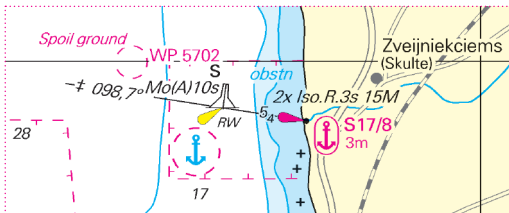

S10 Mitte rechts
S10 centre right

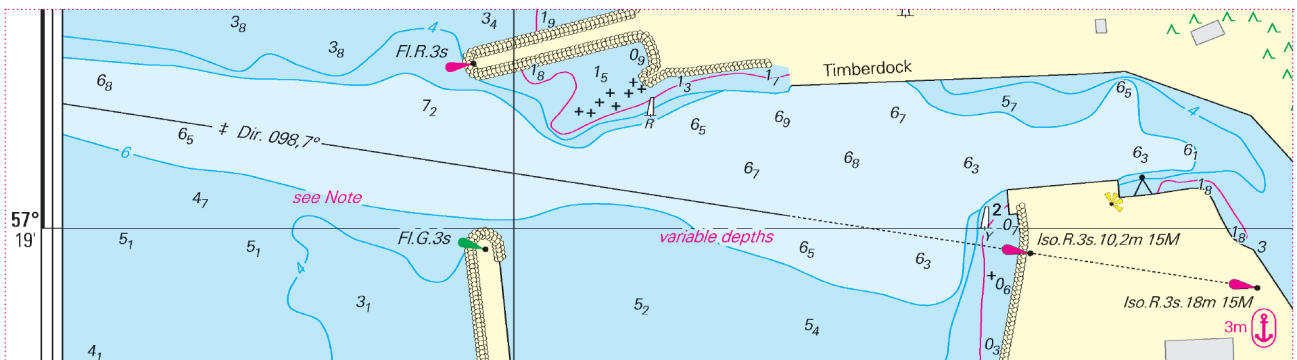

S17/8 Mitte links
S17/8 centre left

20cm

10cm

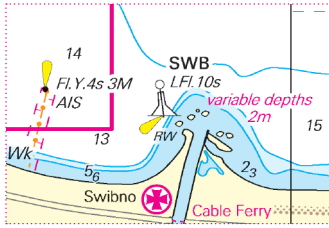

S5 unten Mitte
S5 bottom centre

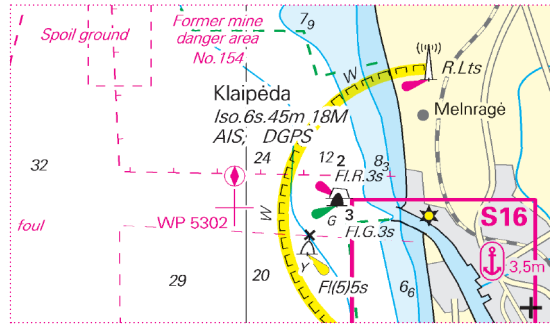

S6 Mitte rechts
S6 centre right

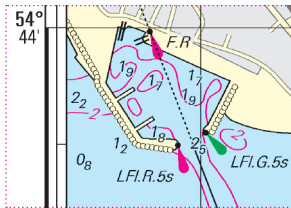

S11/11 oben links
S11/11 top left

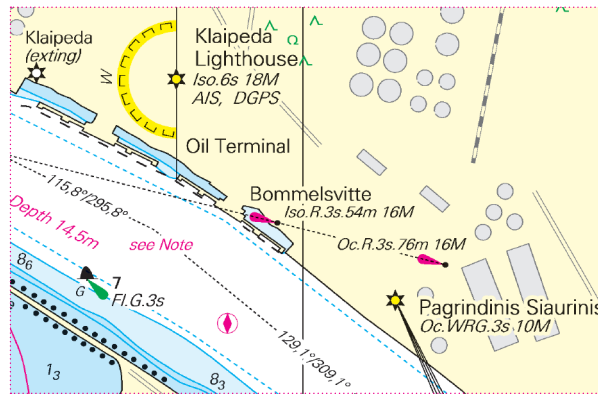

S16 oben links
S16 top left

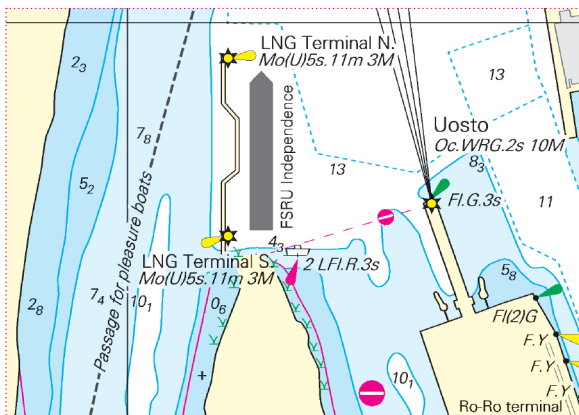

S16 unten rechts
S16 bottom right

20cm

10cm

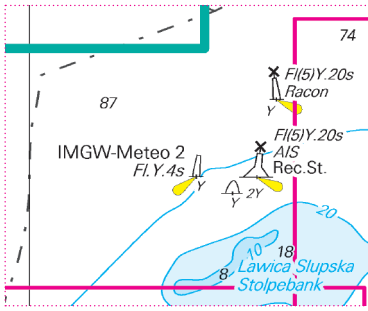

S1 unten links
S1 bottom left

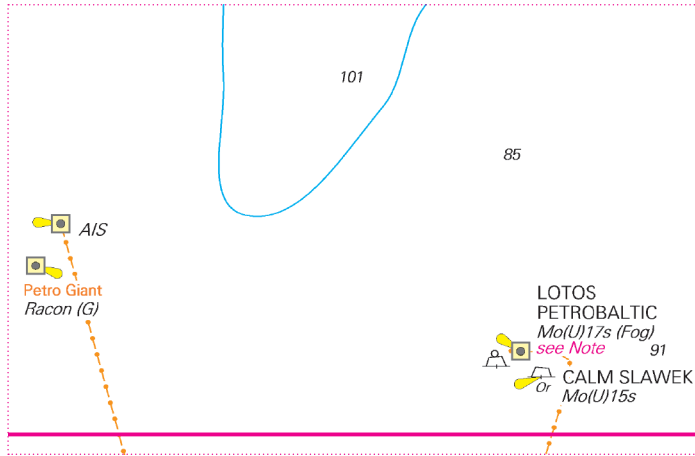

S2 Mitte links
S2 centre left

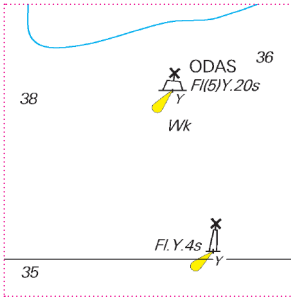

S4 Mitte
S4 centre

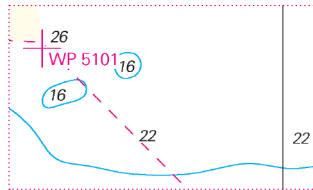

S4 Mitte
S4 centre

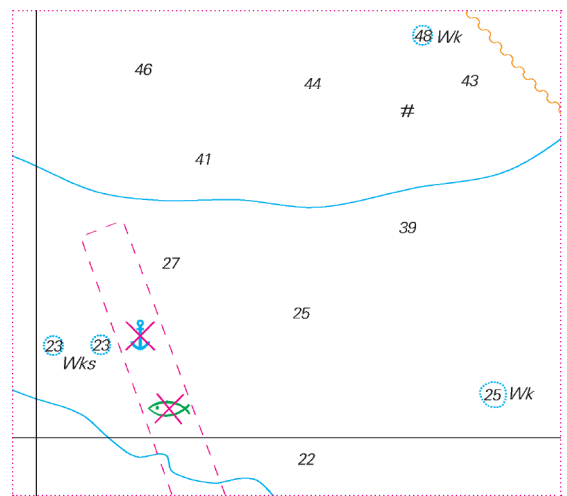

S3 Mitte
S3 centre

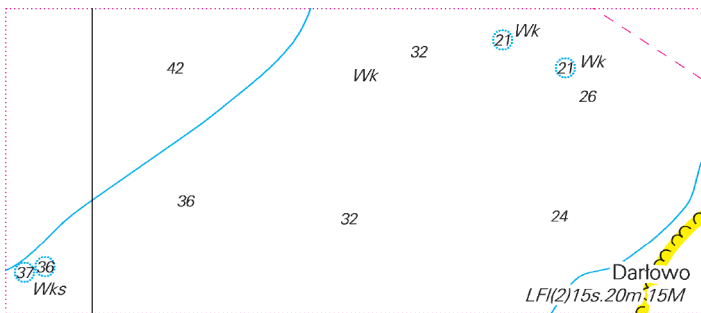

S3 Mitte
S3 centre



S3 Mitte rechts
S3 centre right

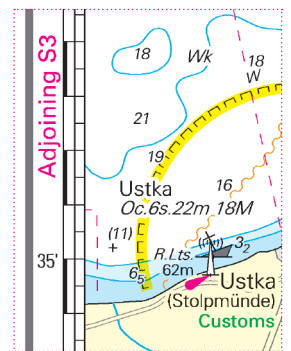

S4 unten links
S4 bottom left

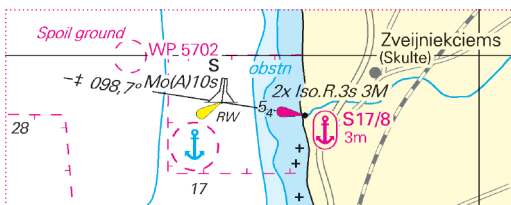

S10 Mitte rechts
S10 centre right

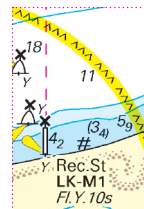

S4 Mitte
S4 centre

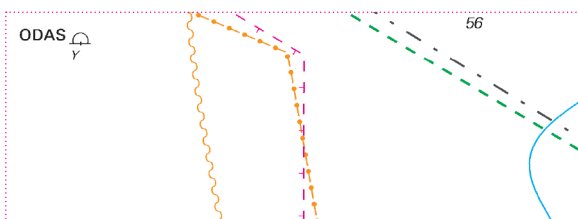

S6 Mitte links
S6 centre left

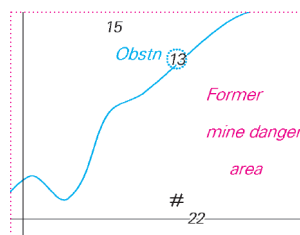

S9 Mitte
S9 centre



S9 Mitte
S9 centre

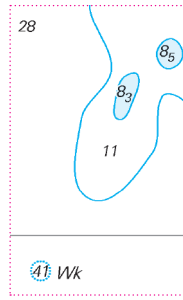
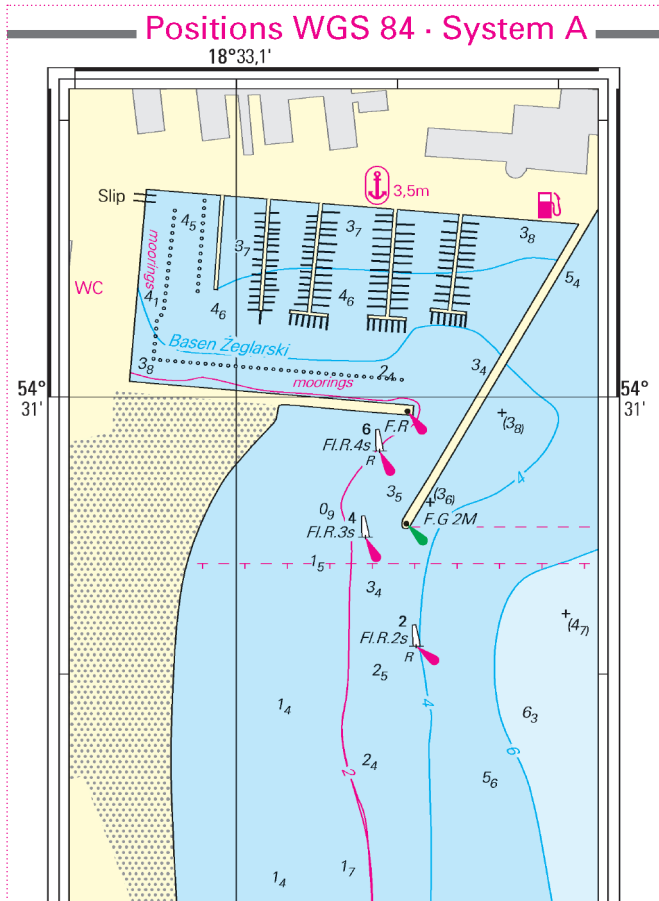

S10 Mitte links
S10 centre left



S10 oben rechts
S10 top right

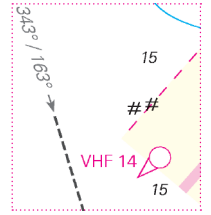

S12 unten Mitte
S12 bottom centre

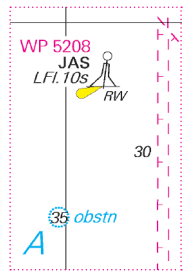

S12 Mitte
S12 centre

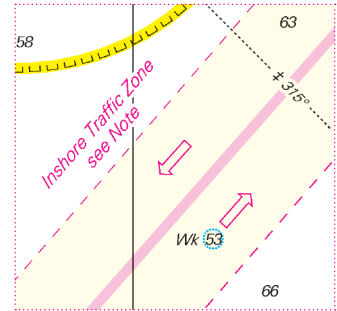

S12 Mitte rechts
S12 centre right

S11/8 oben Mitte
S11/8 top centre



S18 Mitte
S18 centre

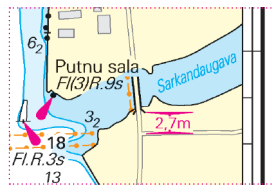

S18 Mitte rechts
S18 centre right

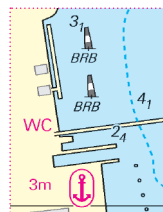

S17/7 unten Mitte
S17/7 bottom centre

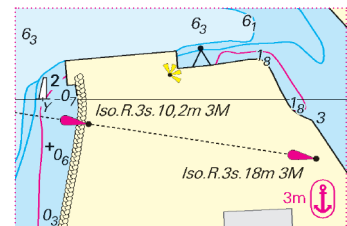

S17/8 Mitte
S17/8 centre

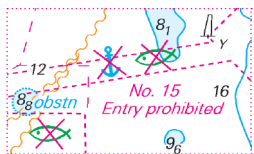

S12 Mitte links
S12 centre left

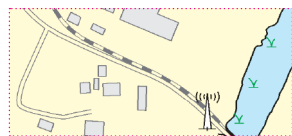

S18 Mitte rechts
S18 centre right

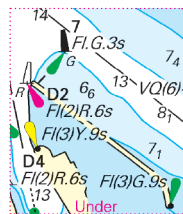

S18 oben Mitte
S18 top centre

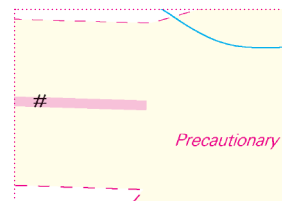

S12 Mitte
S12 centre

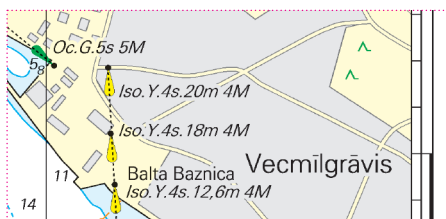

S18 Mitte rechts
S18 centre right

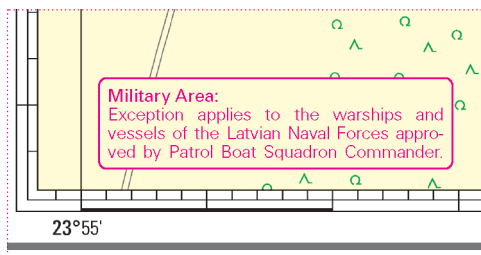

S18 unten links
S18 bottom left

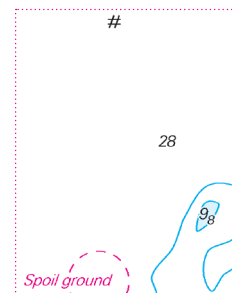

S10 unten Mitte
S10 bottom centre

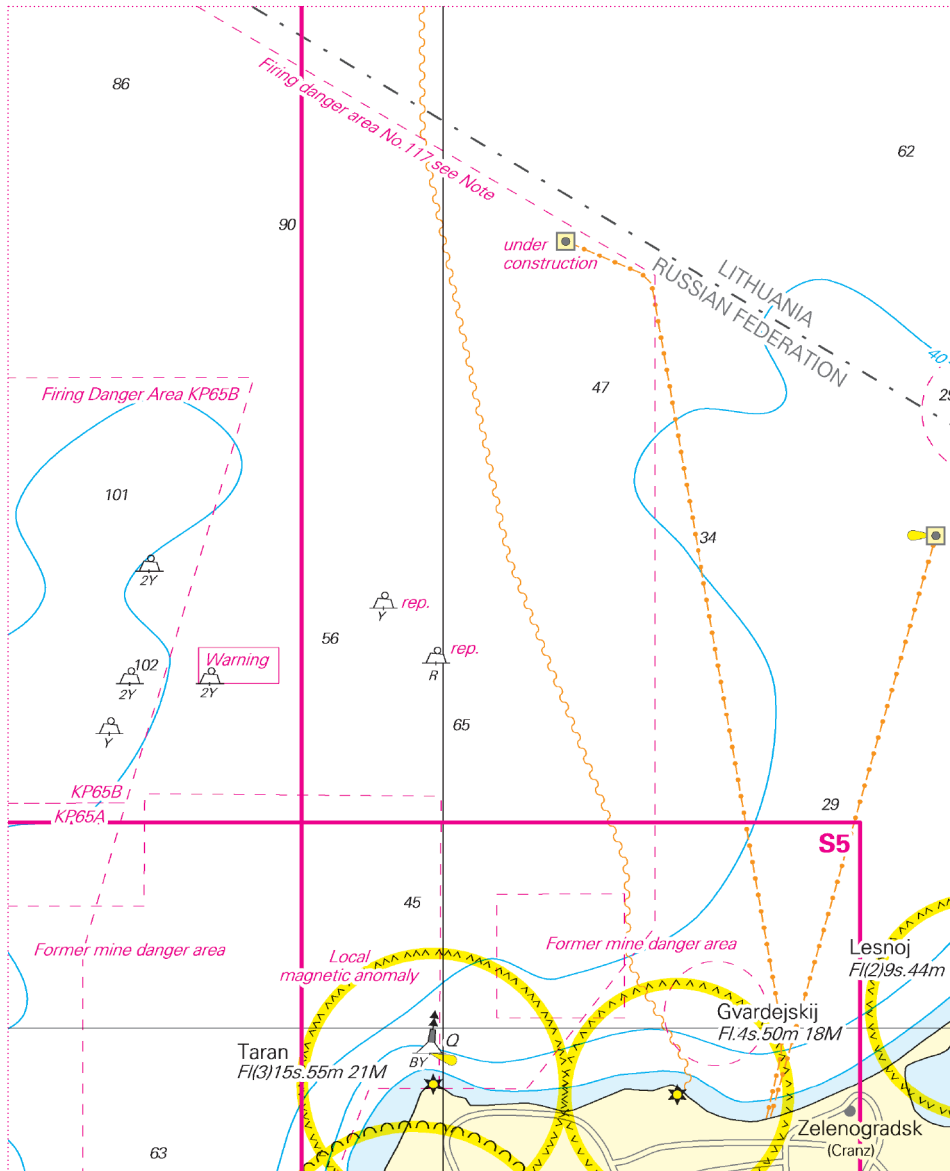

S2 unten rechts
S2 bottom right

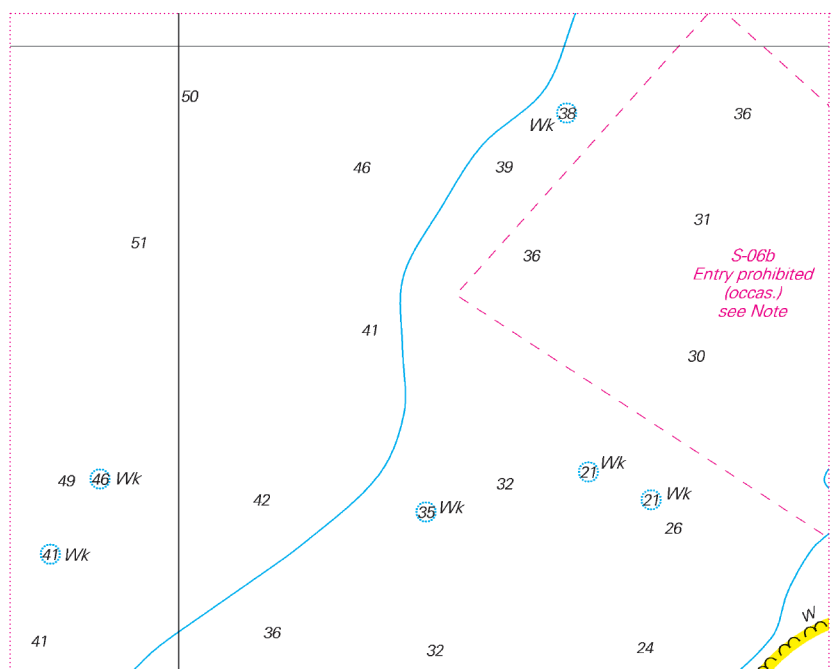

S3 Mitte rechts
S3 centre right

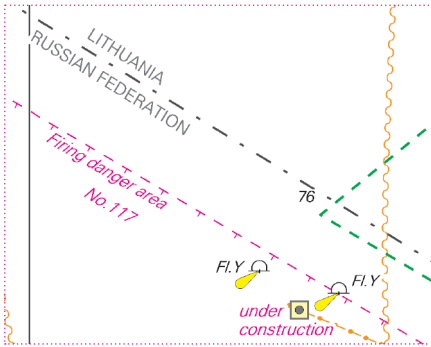

S6 Mitte links
S6 centre left

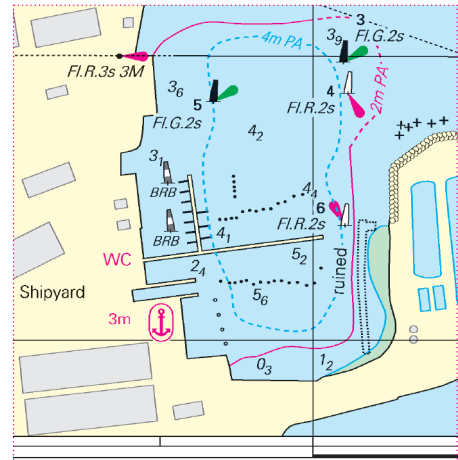

S17/7 unten Mitte
S17/7 bottom centre

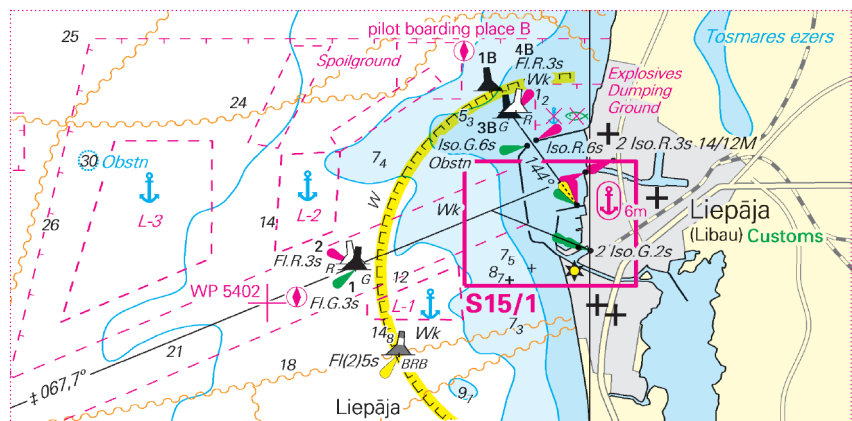

S7 Mitte
S7 centre

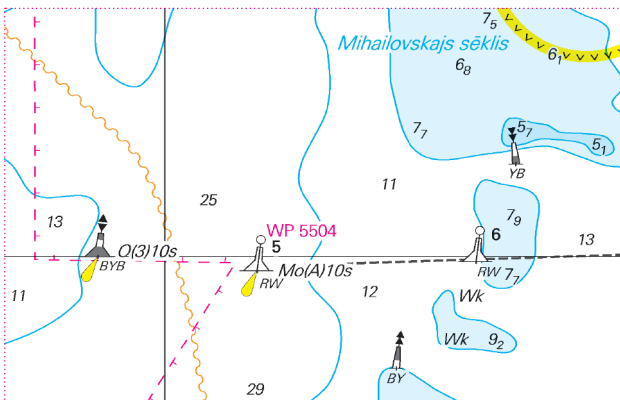

S8 Mitte rechts
S8 centre right

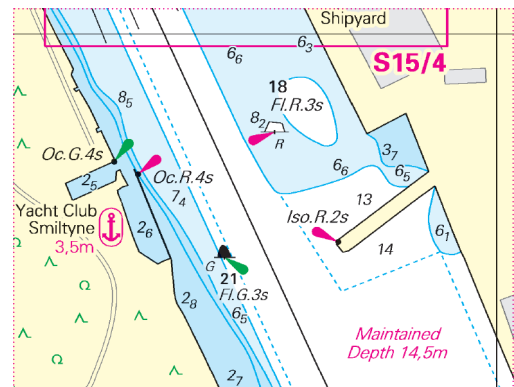

S16 Mitte rechts
S16 centre right

20cm

10cm



Serie 6

Polen-Litauen-Lettland

2025

Update-Service Woche / Week 23

Woche / Week 01-16 2025

Hinweis: Dieses Dokument enthält das bisherige, komplette Jahresupdate. Um unnötige Ausdrücke zu vermeiden, wird darauf hingewiesen, gemäß Bedarf nur die bislang noch nicht benutzten Seiten auszudrucken.

Note: This document contains the entire Update-Service to this date. To avoid unnecessary printouts, only the not yet corrected pages should be printed.

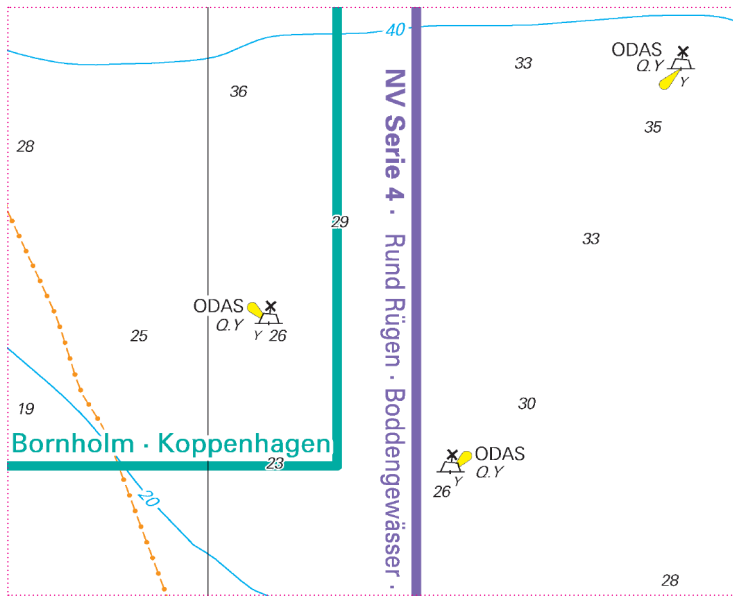

S3 Mitte links
S3 centre left

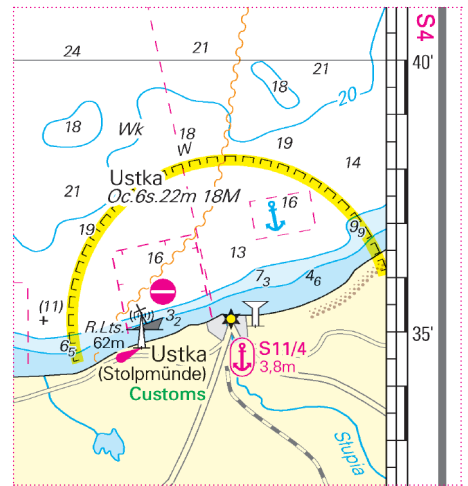

S3 Mitte rechts
S3 centre right

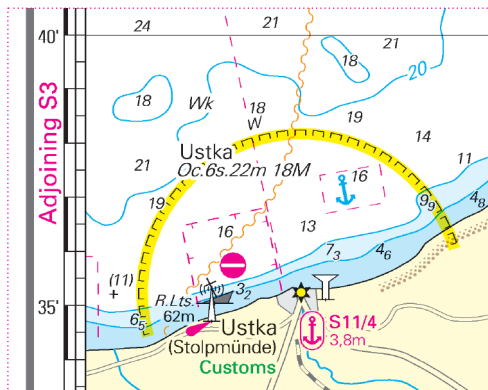

S4 unten links
S4 bottom left

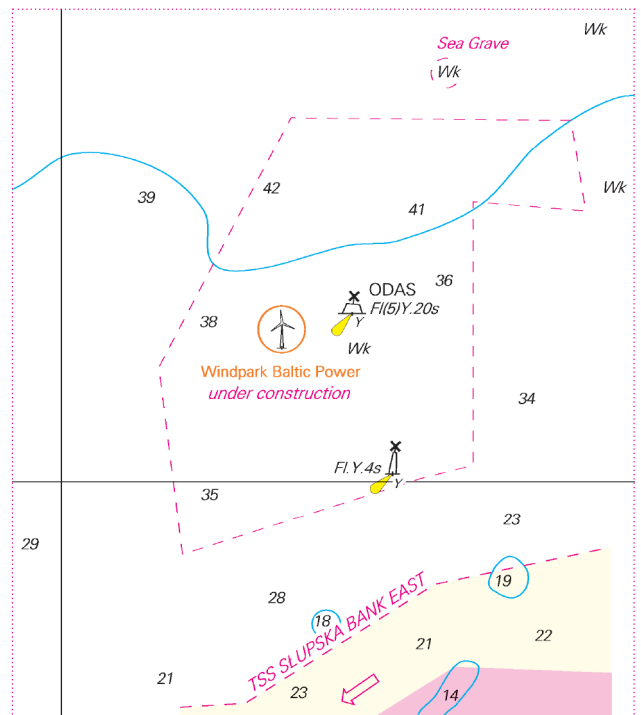

S4 Mitte
S4 centre

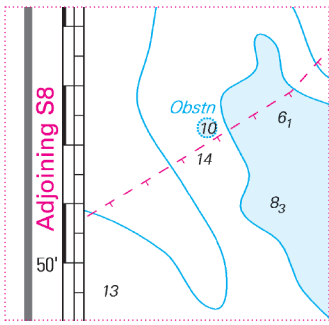

S9 Mitte links
S9 centre left

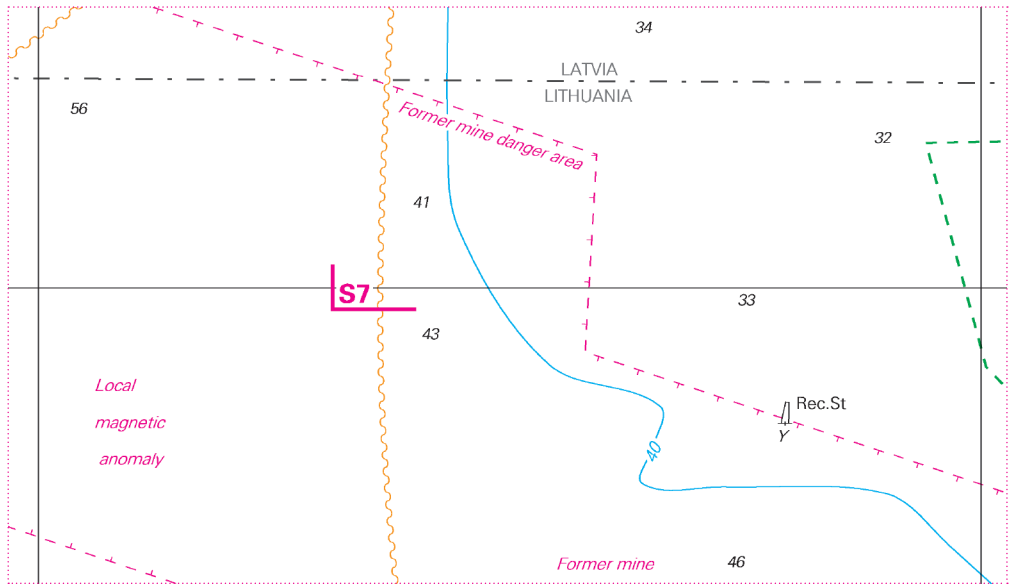

S6 oben links
S6 top left

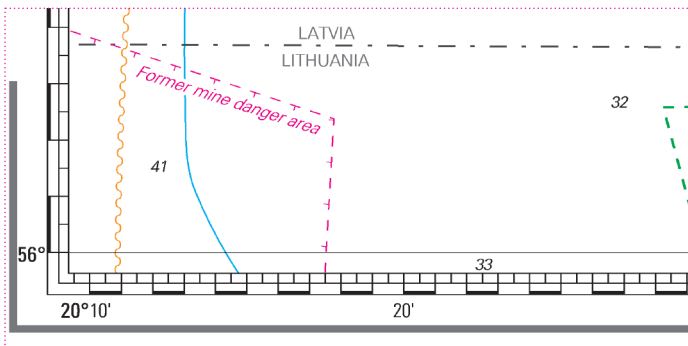

S7 unten links
S7 bottom left

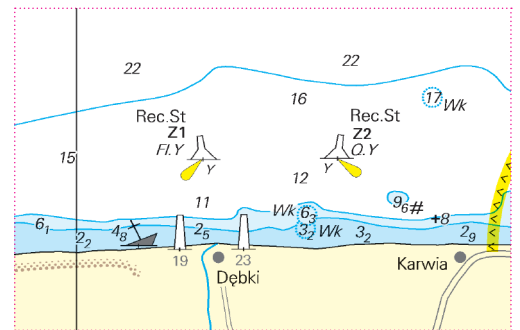

S4 Mitte
S4 centre

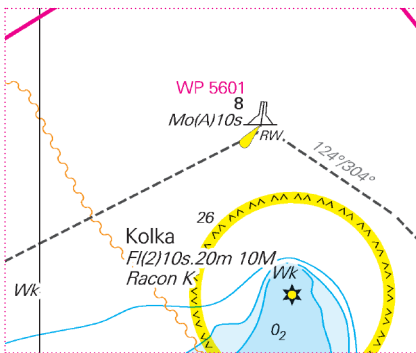

S9 Mitte
S9 centre

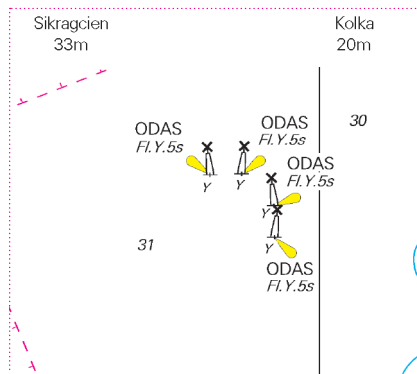

S9 Mitte rechts
S9 centre right

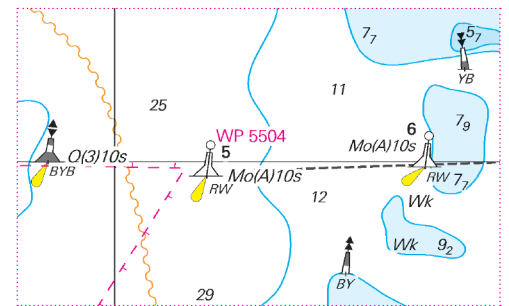

S8 Mitte
S8 centre

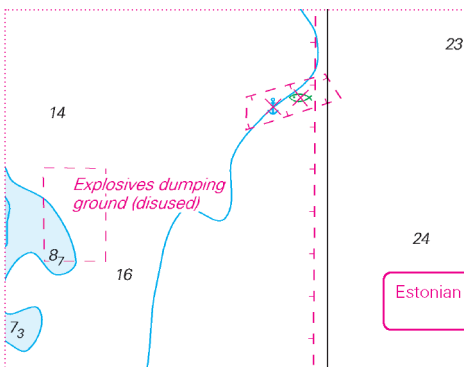

S9 oben rechts
S9 top right

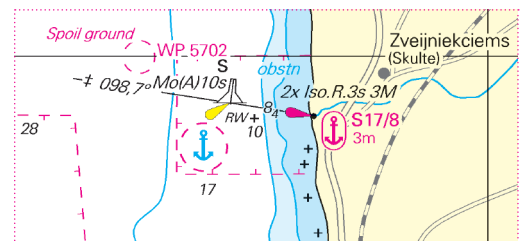

S10 Mitte rechts
S10 centre right

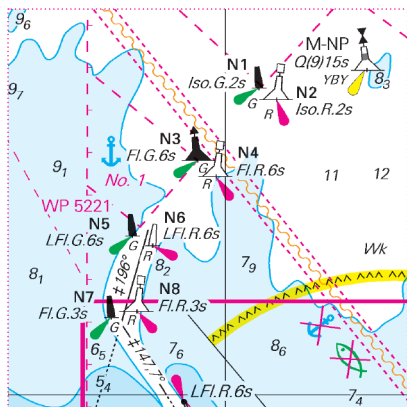

S12 unten Mitte
S12 bottom centre

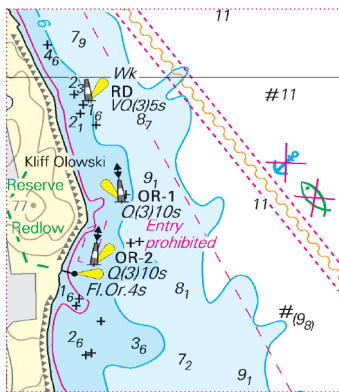

S12 unten Mitte
S12 bottom centre

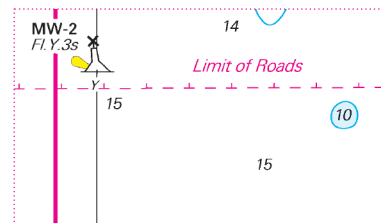

S12 unten rechts
S12 bottom right

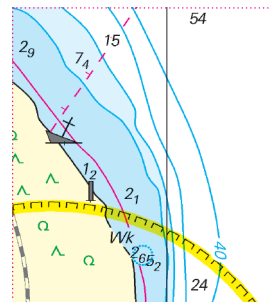

S12 Mitte rechts
S12 centre right

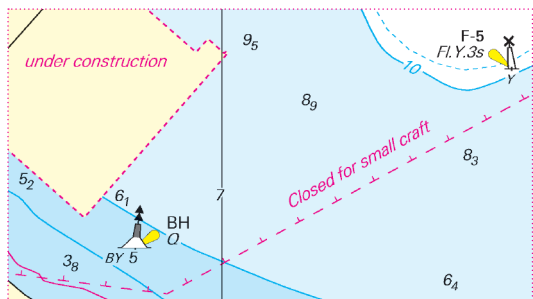

S13 Mitte
S13 centre

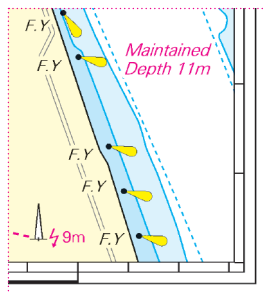

S16 unten rechts
S16 bottom right

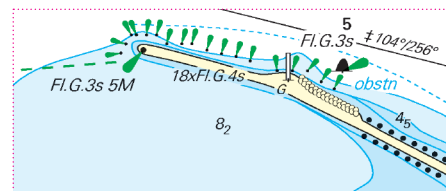

S16 oben links
S16 top left

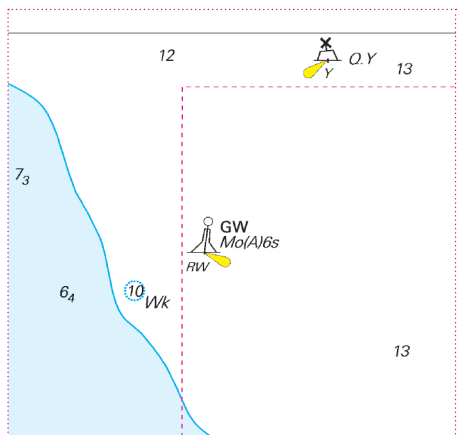

S13 Mitte rechts
S13 centre right

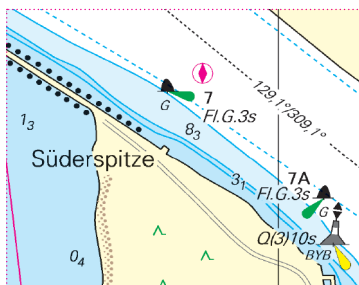

S16 oben Mitte
S16 top centre

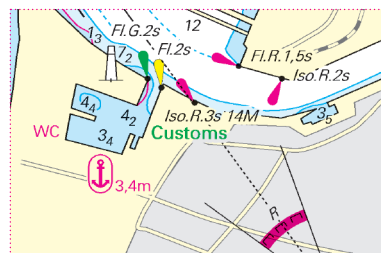

S17/1 unten rechts
S17/1 bottom right

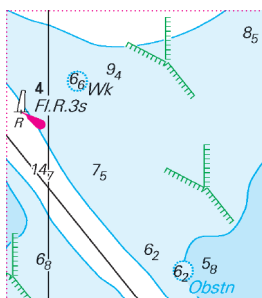

S18 oben Mitte
S18 top centre

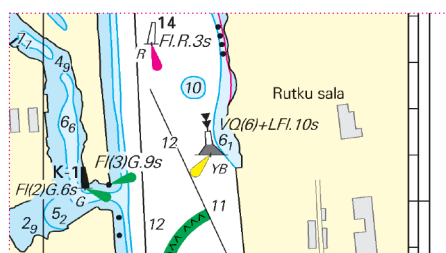

S18 Mitte rechts
S18 centre right

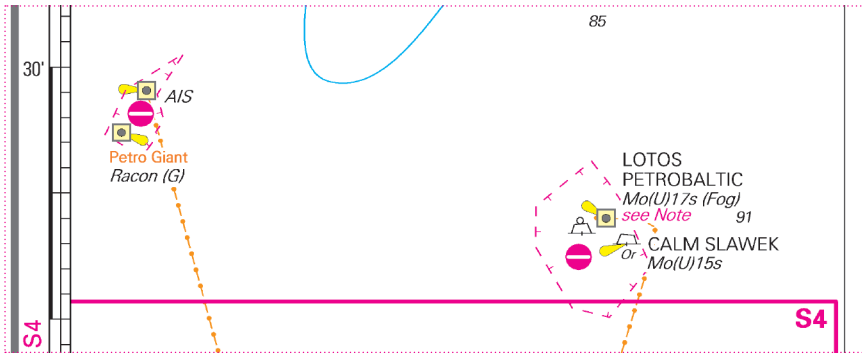

S2 Mitte links
S2 centre left

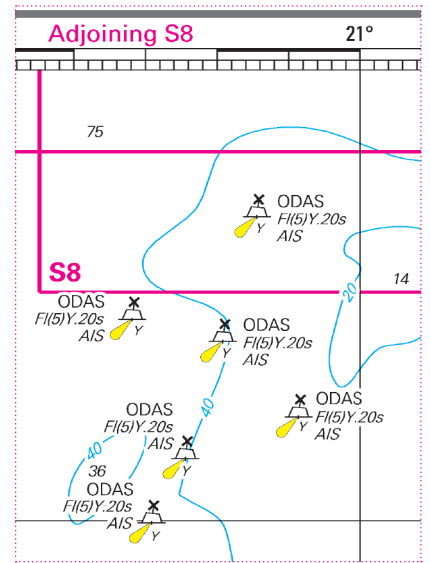

S2 oben rechts
S2 top right

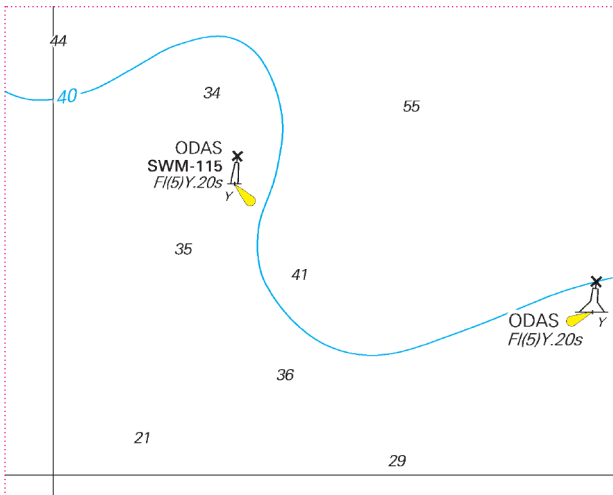

S4 oben links
S4 top left

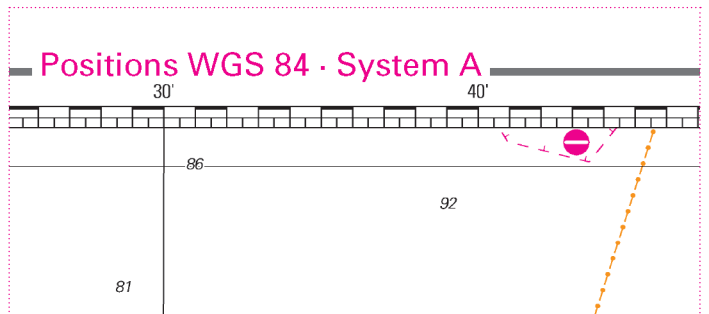

S4 oben rechts
S4 top right

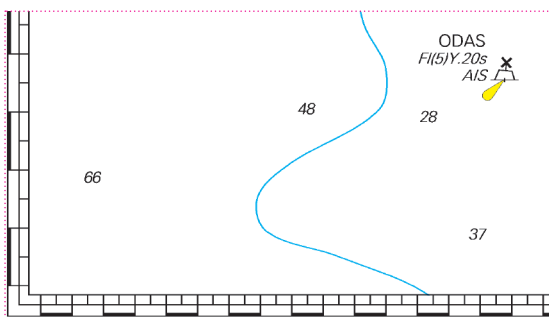

S8 unten links
S8 bottom left

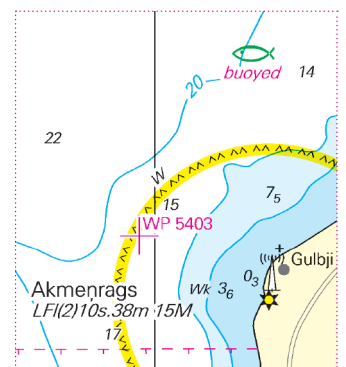

S7 Mitte
S7 centre

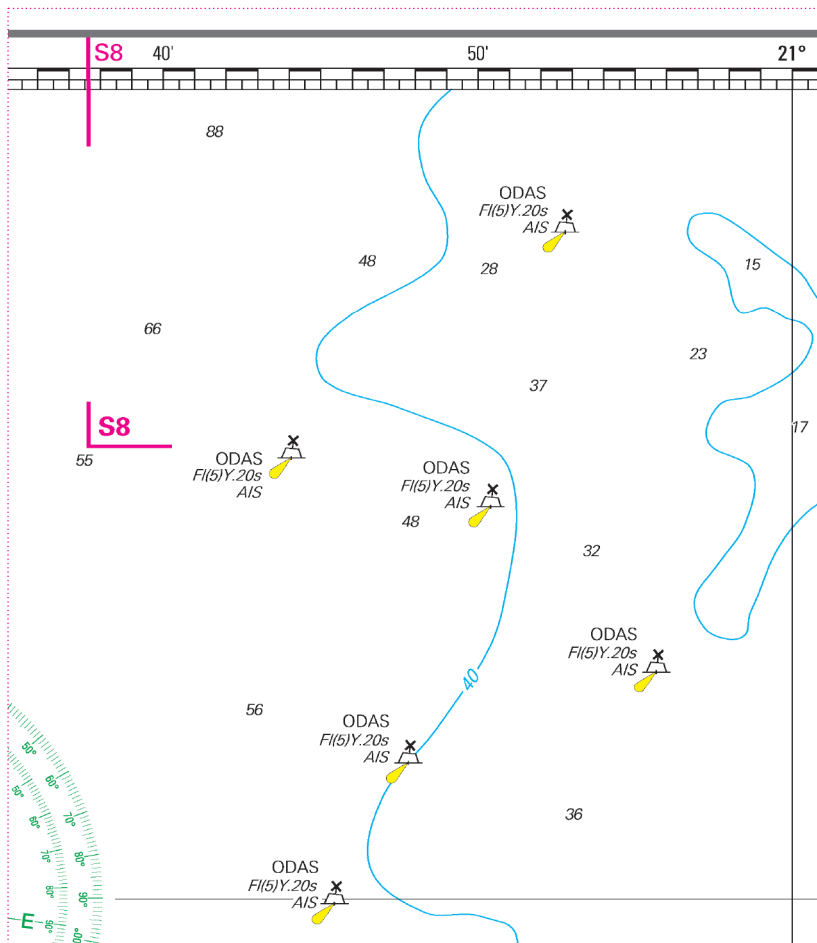

S7 oben Mitte
S7 top centre

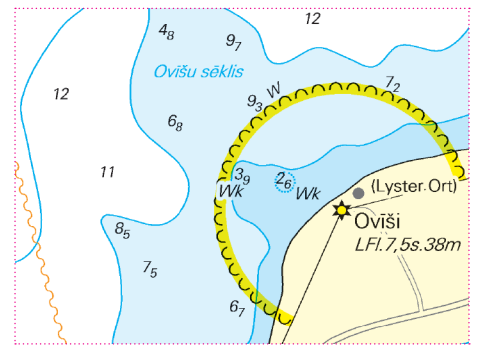

S8 Mitte
S8 centre

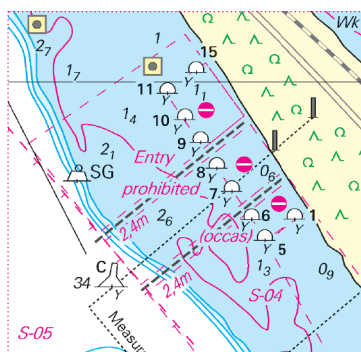

S12 Mitte
S12 centre

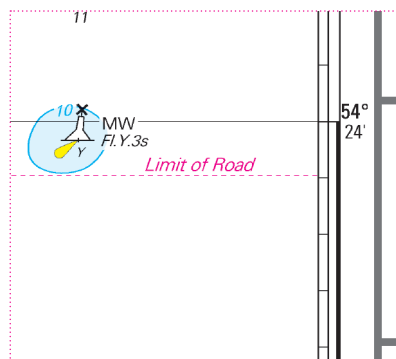

S13 Mitte rechts
S13 centre right

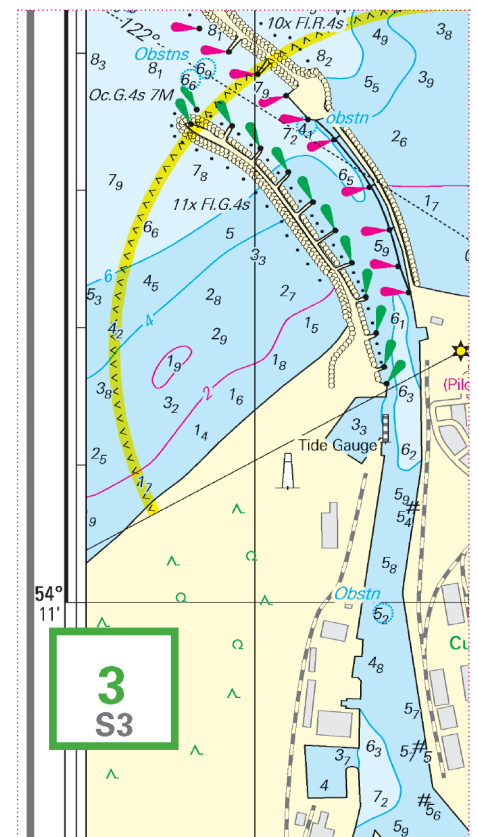

S11/3 Mitte links
S11/3 centre left